

# Model 363 Control Valves

## Technical Sales Bulletin



**Figure 1** Model 363 Control Valve

The Model 363 control valve is part of the 360 Series of control valves.

The Model 363 is a top guided, unbalanced, single port valve that is suitable for either throttling or on off control of either liquids or gases. Metal to metal seating is standard on Model 363 valves with an option for soft seating.

The standard actuator for the Model 363 control valve is a Dyna-Flo Model DFC or DFO linear actuators. These heavy-duty actuators are spring return diaphragm style, and can be used for throttling or on-off service, with or without a valve positioner.

The Model 363 control valves are manufactured to a high level of quality specifications to ensure superior performance and customer satisfaction.

### Features

#### Versatility

Multiple port sizes make the 363 an easy valve to reconfigure when process applications change.

#### Rugged Design

Available severe service trim and high temperature configurations are well suited to more demanding applications.

#### High Temperature Option

The standard temperature rating of 450°F (232°C) can be extended to 850°F (454°C), with options available for higher temperatures.

#### Full Pressure Drop Capabilities

363 control valves can shut off against inlet pressures equal to the ASME B16.34 rating.

#### Sour Gas Service Capability

There are standard construction materials that comply with the recommendations of the National Association of Corrosion Engineers (NACE) MR0175/ISO 15156.

#### Shut Off Capability

Shut off options are available from ANSI/FCI 70.2 and IEC 60534-4 Class II to Class VI.

#### Flow Characteristic Selections

Equal percentage, linear and quick-opening flow characteristics available.

#### Easy Maintenance

As with all 360 Series Valves, the 363 can be serviced in line with no special tools required.



# Model 363 Control Valves

## Technical Sales Bulletin

### SPECIFICATIONS

#### Configurations

The Model 363 control valve is a high capacity single port, globe style valve with a bolted type bonnet. The standard valve plug action is push down to close. Refer to Table 1.

Consult your Dyna-Flo sales office for other available configurations.

#### Sizes and Connection Styles (Refer to Table 1)

Model:	363
Size:	1/2", 3/4", 1", 1-1/2", 2"
Body:	Globe (All Sizes)
Rating:	ASME 150 / 300 / 600
Connection:	RF / RTJ / BWE / SWE / NPT - All Sizes

#### Maximum Inlet Pressures and Temperatures

Flanged valves consistent with ASME Class 150, 300, and 600 rating as per ASME B16.34, unless further limited by factors in Tables 15, 16, 18, 19, 21, 22.

#### Maximum Pressure Drops

Maximum pressure drop is the same as maximum inlet pressure unless restricted by the following:

**Material Temperature Limits:** Tables 15, 16, 18, 19, 21, 22

#### Characteristic and Flow Direction

- Equal Percentage (Standard) - Flow Up
- Quick Opening - Flow Up
- Linear - Flow Up
- Dyna-Form (Equal Percentage) - Flow Up
- Dyna-Flute 1 (Equal Percentage) - Flow Up
- Dyna-Flute 3 (Equal Percentage) - Flow Up
- Dyna-Flat (Equal Percentage) - Flow Up

#### Dimensions

##### Valve and Actuator Outline Dimension Diagram

Refer to Figure 2.

##### Valve and Actuator Assembly Dimensions

Refer to Tables 5 to 13.

#### Approximate Valve Body and Actuator Weights

Refer to Table 3.

#### Materials

Body and bonnet material options include:

LCC (A350-LF2 optional\* bonnet material)

WCC (A350-LF2 optional\* bonnet material)

WC9 (A182-F22 optional\* bonnet material)

CF8M (A182-F316 optional\* bonnet material)

**\*NOTE:** Dyna-Flo reserves the right to substitute a cast material with the forged bar equivalent in the event a casting is not available.

Refer to Figure 14 for valve construction material temperature limitations. Refer to Table 19 for trim selections.

#### Cross-Section of the Model 363 Control Valves

Refer to Figure 3.

#### Port Diameters and Maximum Valve Plug Travel

Refer to Tables 4 to 5.

#### Packing Type and Examples

The Standard packing is PTFE V-ring. Live-loaded low emission, graphite, KALREZ® and other packing arrangements are available. Refer to Figure 8.

#### Maximum Valve Sizing Coefficients

For standard coefficients at maximum travel, refer to Tables 27 & 28. For full list of coefficients refer to document P-CVSM.

For more information and other options contact your Dyna-Flo sales office.

# Model 363 Control Valves

## Technical Sales Bulletin



**Table 1**

**Standard Shut-Off Classifications** (in accordance with ANSI/FCI 70.2 and IEC 60534-4)

Valve Trim	Seat Option	Shut-Off Class	
All	Metal	Standard	Class IV
		Optional	Class V
			Class VI <sup>(1)</sup>
<b>Notes:</b>		1 - Refer to Tables 2 & 19.	

**Table 2**

**Class VI Valve Shut-off Configurations**

Port Size	Seat	Minimum Seat Load
All	Metal	300 lbs / Lineal Inch

**Table 3**

**Valve Body and Actuator Assembly Approximate Weights**

Valve Size (Inch)	Body Only lb (Kg)	With Fail Closed Actuator	Assembly Weight lb (Kg)	With Fail Open Actuator	Assembly Weight lb (Kg)
<b>1/2</b>	30 (14)	DFC - 1069	78 (26)	DFO - 1069	70 (32)
<b>3/4</b>	30 (14)	DFC - 1069	78 (26)	DFO - 1069	70 (32)
<b>1</b>	30 (14)	DFC - 1069	78 (26)	DFO - 1069	70 (32)
<b>1-1/2</b>	45 (20)	DFC - 1069	93 (42)	DFO - 1069	85 (39)
<b>2</b>	85 (39)	DFC - 2069	135 (61)	DFO - 2069	136 (62)
		DFC - 2105	175 (79)	DFO - 2105	167 (76)
		DFC - 2156	206 (94)	DFO - 2156	192 (87)



# Model 363 Control Valves

## Technical Sales Bulletin

**Table 4**

**Full Port Valves - Port Diameters, Valve Travel and Mounting Connection**

Characteristic	Valve Size inch	Port Size inch (mm)	Max Valve Travel inch (mm)	Valve Stem and Mounting Connection Diameter inch (mm)			
				Standard		Optional	
				Stem	Yoke Boss	Stem	Yoke Boss
Equal Percentage	1	1 (25.4)	3/4 (19.1)	3/8 (9.5)	2-1/8 (54)	1/2 (12.7)	2-13/16 (71)
	1-1/2	1-1/2 (38.1)					
	2	2 (50.8)	1-1/8 (28.6)	1/2 (12.7)	2-13/16 (71)	3/4 (19.1)	3-9/16 (90)
Dyna-Form (Equal Percentage)	1/2	1/2 (12.7)	3/4 (19.1)	3/8 (9.5)	2-1/8 (54)	1/2 (12.7)	2-13/16 (71)
	3/4	3/4 (19.1)					
Linear	1	1 (25.4)	3/4 (19.1)	3/8 (9.5)	2-1/8 (54)	1/2 (12.7)	2-13/16 (71)
	1-1/2	1-1/2 (38.1)					
	2	2 (50.8)	1-1/8 (28.6)	1/2 (12.7)	2-13/16 (71)	3/4 (19.1)	3-9/16 (90)
Quick Opening	1/2	1 (25.4)	3/4 (19.1)	3/8 (9.5)	2-1/8 (54)	1/2 (12.7)	2-13/16 (71)
	3/4	1 (25.4)					
	1	1 (25.4)					
	1-1/2	1-1/2 (38.1)	1-1/8 (28.6)	1/2 (12.7)	2-13/16 (71)	3/4 (19.1)	3-9/16 (90)
	2	2 (50.8)					

# Model 363 Control Valves

## Technical Sales Bulletin



Table 5

### Reduced Port Valves - Port Diameters, Valve Travel and Mounting Connection

Characteristic	Valve Size	Port Size	Max Valve Travel	Valve Stem and Mounting Connection Diameter inch (mm)			
				Standard		Optional	
				Stem	Yoke Boss	Stem	Yoke Boss
Equal Percentage	1-1/2	1 (25.4)	3/4 (19.1)	3/8 (9.5)	2-1/8 (54)	1/2 (12.7)	2-13/16 (71)
	2	1 (25.4)	3/4 (19.1)	1/2 (12.7)	2-13/16 (71)	-	-
Dyna-Form (Equal Percentage)	1/2	1/4 (6.4)	3/4 (19.1)	3/8 (9.5)	2-1/8 (54)	1/2 (12.7)	2-13/16 (71)
		3/8 (9.5)					
	3/4	1/4 (6.4)	3/4 (19.1)	3/8 (9.5)	2-1/8 (54)	1/2 (12.7)	2-13/16 (71)
		3/8 (9.5)					
		1/2 (12.7)					
	1	1/4 (6.4)	3/4 (19.1)	3/8 (9.5)	2-1/8 (54)	1/2 (12.7)	2-13/16 (71)
1-1/2	3/8 (9.5)						
2	1/2 (12.7)	3/4 (19.1)	1/2 (12.7)	2-13/16 (71)	-	-	
	3/4 (19.1)						
Linear	1-1/2	1 (25.4)	3/4 (19.1)	3/8 (9.5)	2-1/8 (54)	1/2 (12.7)	2-13/16 (71)
	2	1 (25.4)	3/4 (19.1)	1/2 (12.7)	2-13/16 (71)	-	-
Quick Opening	1-1/2	1 (25.4)	3/4 (19.1)	3/8 (9.5)	2-1/8 (54)	1/2 (12.7)	2-13/16 (71)
	2	1 (25.4)	3/4 (19.1)	1/2 (12.7)	2-13/16 (71)	-	-
Dyna-Flute 1 and 3 Flute (Equal Percentage)	1/2	1/4 (6.4)	3/4 (19.1)	3/8 (9.5)	2-1/8 (54)	1/2 (12.7)	2-13/16 (71)
	3/4						
	1						
	1-1/2						
	2						
Dyna-Flat (Equal Percentage) 3D25M 1D55M 1D8M 1D	1/2	1/4 (6.4) 3/16 (4.8)	3/4 (19.1)	3/8 (9.5)	2-1/8 (54)	1/2 (12.7)	2-13/16 (71)
	3/4						
	1						
	1-1/2						
	2	1/4 (6.4) 3/16 (4.8)	3/4 (19.1)	1/2 (12.7)	2-13/16 (71)	-	-



# Model 363 Control Valves

## Technical Sales Bulletin

**Table 6**

**Valve Assembly (RF End Connection and Standard Bonnet) with Actuator Envelope Dimensions**

Inches (mm) (Refer to Figure 2)

Valve Size (inch)	Pressure Rating	Actuator Size	A	B	C	D		E
						DFC	DFO	
1/2	ASME Class 150	1069	7.25 (184)	2.38 (60)	5.00 (127)	27.68 (703)	24.25 (616)	13.12 (333)
	ASME Class 300	1069	7.75 (197)	2.38 (60)	5.00 (127)	27.68 (703)	24.25 (616)	13.12 (333)
	ASME Class 600	1069	8.25 (210)	2.38 (60)	5.00 (127)	27.68 (703)	24.25 (616)	13.12 (333)
3/4	ASME Class 150	1069	7.25 (184)	2.38 (60)	5.00 (127)	27.68 (703)	24.25 (616)	13.12 (333)
	ASME Class 300	1069	7.75 (197)	2.38 (60)	5.00 (127)	27.68 (703)	24.25 (616)	13.12 (333)
	ASME Class 600	1069	8.25 (210)	2.38 (60)	5.00 (127)	27.68 (703)	24.25 (616)	13.12 (333)
1	ASME Class 150	1069	7.25 (184)	2.38 (60)	5.00 (127)	27.68 (703)	24.25 (616)	13.12 (333)
	ASME Class 300	1069	7.75 (197)	2.38 (60)	5.00 (127)	27.68 (703)	24.25 (616)	13.12 (333)
	ASME Class 600	1069	8.25 (210)	2.38 (60)	5.00 (127)	27.68 (703)	24.25 (616)	13.12 (333)
1-1/2	ASME Class 150	1069	8.75 (222)	2.81 (71)	4.88 (124)	27.56 (700)	24.13 (613)	13.12 (333)
	ASME Class 300	1069	9.25 (235)	2.81 (71)	4.88 (124)	27.56 (700)	24.13 (613)	13.12 (333)
	ASME Class 600	1069	9.88 (251)	2.81 (71)	4.88 (124)	27.56 (700)	24.13 (613)	13.12 (333)
2	ASME Class 150	2069	10.00 (254)	3.06 (78)	6.50 (165)	29.88 (759)	27.70 (704)	13.12 (333)
	ASME Class 150	2105	10.00 (254)	3.06 (78)	6.50 (165)	36.75 (933)	32.22 (818)	16.00 (406)
	ASME Class 300	2069	10.50 (267)	3.06 (78)	6.50 (165)	29.88 (759)	27.70 (704)	13.12 (333)
	ASME Class 300	2105	10.50 (267)	3.06 (78)	6.50 (165)	36.75 (933)	32.22 (818)	16.00 (406)
	ASME Class 600	2069	11.25 (286)	3.06 (78)	6.50 (165)	29.88 (759)	27.70 (704)	13.12 (333)
	ASME Class 600	2105	11.25 (286)	3.06 (78)	6.50 (165)	36.75 (933)	32.22 (818)	16.00 (406)
	ASME Class 600	2156	11.25 (286)	3.06 (78)	6.50 (165)	36.75 (933)	32.22 (818)	18.62 (473)

# Model 363 Control Valves

## Technical Sales Bulletin



**Table 7**

**Valve Assembly (RTJ End Connection and Standard Bonnet) with Actuator Envelope Dimensions**  
Inches (mm) (Refer to Figure 2)

Valve Size (inch)	Pressure Rating	Actuator Size	A	B	C	D		E
						DFC	DFO	
1/2	ASME Class 150	1069	7.75 (197)	2.38 (60)	5.00 (127)	27.68 (703)	24.25 (616)	13.12 (333)
	ASME Class 300	1069	8.25 (210)	2.38 (60)	5.00 (127)	27.68 (703)	24.25 (616)	13.12 (333)
	ASME Class 600	1069	8.25 (210)	2.38 (60)	5.00 (127)	27.68 (703)	24.25 (616)	13.12 (333)
3/4	ASME Class 150	1069	7.75 (197)	2.38 (60)	5.00 (127)	27.68 (703)	24.25 (616)	13.12 (333)
	ASME Class 300	1069	8.25 (210)	2.38 (60)	5.00 (127)	27.68 (703)	24.25 (616)	13.12 (333)
	ASME Class 600	1069	8.25 (210)	2.38 (60)	5.00 (127)	27.68 (703)	24.25 (616)	13.12 (333)
1	ASME Class 150	1069	7.75 (197)	2.38 (60)	5.00 (127)	27.68 (703)	24.25 (616)	13.12 (333)
	ASME Class 300	1069	8.25 (210)	2.38 (60)	5.00 (127)	27.68 (703)	24.25 (616)	13.12 (333)
	ASME Class 600	1069	8.25 (210)	2.38 (60)	5.00 (127)	27.68 (703)	24.25 (616)	13.12 (333)
1-1/2	ASME Class 150	1069	9.25 (235)	2.81 (71)	4.88 (124)	27.56 (700)	24.13 (613)	13.12 (333)
	ASME Class 300	1069	9.75 (248)	2.81 (71)	4.88 (124)	27.56 (700)	24.13 (613)	13.12 (333)
	ASME Class 600	1069	9.88 (251)	2.81 (71)	4.88 (124)	27.56 (700)	24.13 (613)	13.12 (333)
2	ASME Class 150	2069	10.50 (267)	3.06 (78)	6.50 (165)	29.88 (759)	27.70 (704)	13.12 (333)
	ASME Class 150	2105	10.50 (267)	3.06 (78)	6.50 (165)	36.75 (933)	32.22 (818)	16.00 (406)
	ASME Class 300	2069	11.12 (282)	3.06 (78)	6.50 (165)	29.88 (759)	27.70 (704)	13.12 (333)
	ASME Class 300	2105	11.12 (282)	3.06 (78)	6.50 (165)	36.75 (933)	32.22 (818)	16.00 (406)
	ASME Class 600	2069	11.38 (289)	3.06 (78)	6.50 (165)	29.88 (759)	27.70 (704)	13.12 (333)
	ASME Class 600	2105	11.38 (289)	3.06 (78)	6.50 (165)	36.75 (933)	32.22 (818)	16.00 (406)
	ASME Class 600	2156	11.38 (289)	3.06 (78)	6.50 (165)	36.75 (933)	32.22 (818)	18.62 (473)

# Model 363 Control Valves

## Technical Sales Bulletin



**Table 8**

**Valve Assembly (NPT End Connection and Standard Bonnet) with Actuator Envelope Dimensions**

Inches (mm) (Refer to Figure 2)

Valve Size (inch)	Pressure Rating	Actuator Size	A	B	C	D		E
						DFC	DFO	
1/2	ASME Class 600 NPT	1069	8.25 (210)	2.38 (60)	5.00 (127)	27.68 (703)	24.25 (616)	13.12 (333)
3/4	ASME Class 600 NPT	1069	8.25 (210)	2.38 (60)	5.00 (127)	27.68 (703)	24.25 (616)	13.12 (333)
1	ASME Class 600 NPT	1069	8.25 (210)	2.38 (60)	5.00 (127)	27.68 (703)	24.25 (616)	13.12 (333)
1-1/2	ASME Class 600 NPT	1069	9.88 (251)	2.81 (71)	4.88 (124)	27.56 (700)	24.13 (613)	13.12 (333)
2	ASME Class 600 NPT	2069	11.25 (286)	3.06 (78)	6.50 (165)	29.88 (759)	27.70 (704)	13.12 (333)
	ASME Class 600 NPT	2105	11.25 (286)	3.06 (78)	6.50 (165)	36.75 (933)	32.22 (818)	16.00 (406)
	ASME Class 600 NPT	2156	11.25 (286)	3.06 (78)	6.50 (165)	36.75 (933)	32.22 (818)	18.62 (473)



# Model 363 Control Valves

## Technical Sales Bulletin



**Table 9**

**Valve Body Dimensions with BWE\* End Connection** Inches (mm)  
For 'C' Dimensions refer to Tables 11 to 14 on Pages 9 & 10.

Valve Size Inch	Globe Body	
	A	B
1/2	8.25 (210)	2.38 (60)
3/4	8.25 (210)	2.38 (60)
1	8.25 (210)	2.38 (60)
1-1/2	9.88 (251)	2.81 (71)
2	11.25 (286)	3.06 (78)

\*NOTE: BWE - Butt weld.

**Table 10**

**Valve Body Dimensions with SWE\* End Connection** Inches (mm)  
For 'C' Dimensions refer to Tables 11 to 14 on Pages 9 & 10.

Valve Size Inch	Globe Body	
	A	B
1/2	8.25 (210)	2.38 (60)
3/4	8.25 (210)	2.38 (60)
1	8.25 (210)	2.38 (60)
1-1/2	9.88 (251)	2.81 (71)
2	11.25 (286)	3.06 (78)

\*NOTE: SWE - Socket weld.

**Table 11**

**Standard Bonnet Dimensions**  
inch (mm) (Refer to Figure 2)

Valve Size (Inch)	C		
	Stem Diameter inch (mm)		
	3/8 (9.5)	1/2 (12.7)	3/4 (19.1)
1/2	5.00 (127)	5.88 (149)	—
3/4	5.00 (127)	5.88 (149)	—
1	5.00 (127)	5.88 (149)	—
1-1/2	4.88 (124)	5.75 (146)	—
2	—	6.50 (165)	6.38 (162)



# Model 363 Control Valves

## Technical Sales Bulletin

**Table 12**

### Extension (Style 1) Bonnet Dimensions

Inch (mm) (Refer to Figure 2)

Valve Size (Inch)	C		
	Stem Diameter inch (mm)		
	3/8 (9.5)	1/2 (12.7)	3/4 (19.1)
1/2	8.38 (213)	9.88 (251)	—
3/4	8.38 (213)	9.88 (251)	—
1	8.38 (213)	9.88 (251)	—
1-1/2	8.25 (210)	9.75 (248)	—
2	—	10.50 (267)	10.69 (272)

**Table 13**

### Extension (Style 2) Bonnet Dimensions

Inch (mm) (Refer to Figure 2)

Valve Size (Inch)	C		
	Stem Diameter inch (mm)		
	3/8 (9.5)	1/2 (12.7)	3/4 (19.1)
1/2	11.94 (303)	12.56 (319)	—
3/4	11.94 (303)	12.56 (319)	—
1	11.94 (303)	12.56 (319)	—
1-1/2	11.81 (300)	12.44 (316)	—
2	—	18.31 (465)	—

**Table 14**

### Bellows Seal Bonnet Dimensions

Inch (mm) (Refer to Figure 2)

Valve Size (Inch)	C		
	Stem Diameter inch (mm)		
	3/8 (9.5)	1/2 (12.7)	3/4 (19.1)
1/2	12.59 (320)	Consult Dyna-Flo	—
3/4	12.59 (320)	Consult Dyna-Flo	—
1	12.59 (320)	Consult Dyna-Flo	—
1-1/2	12.47 (317)	Consult Dyna-Flo	—
2	—	15.09 (383)	—

# Model 363 Control Valves

## Technical Sales Bulletin

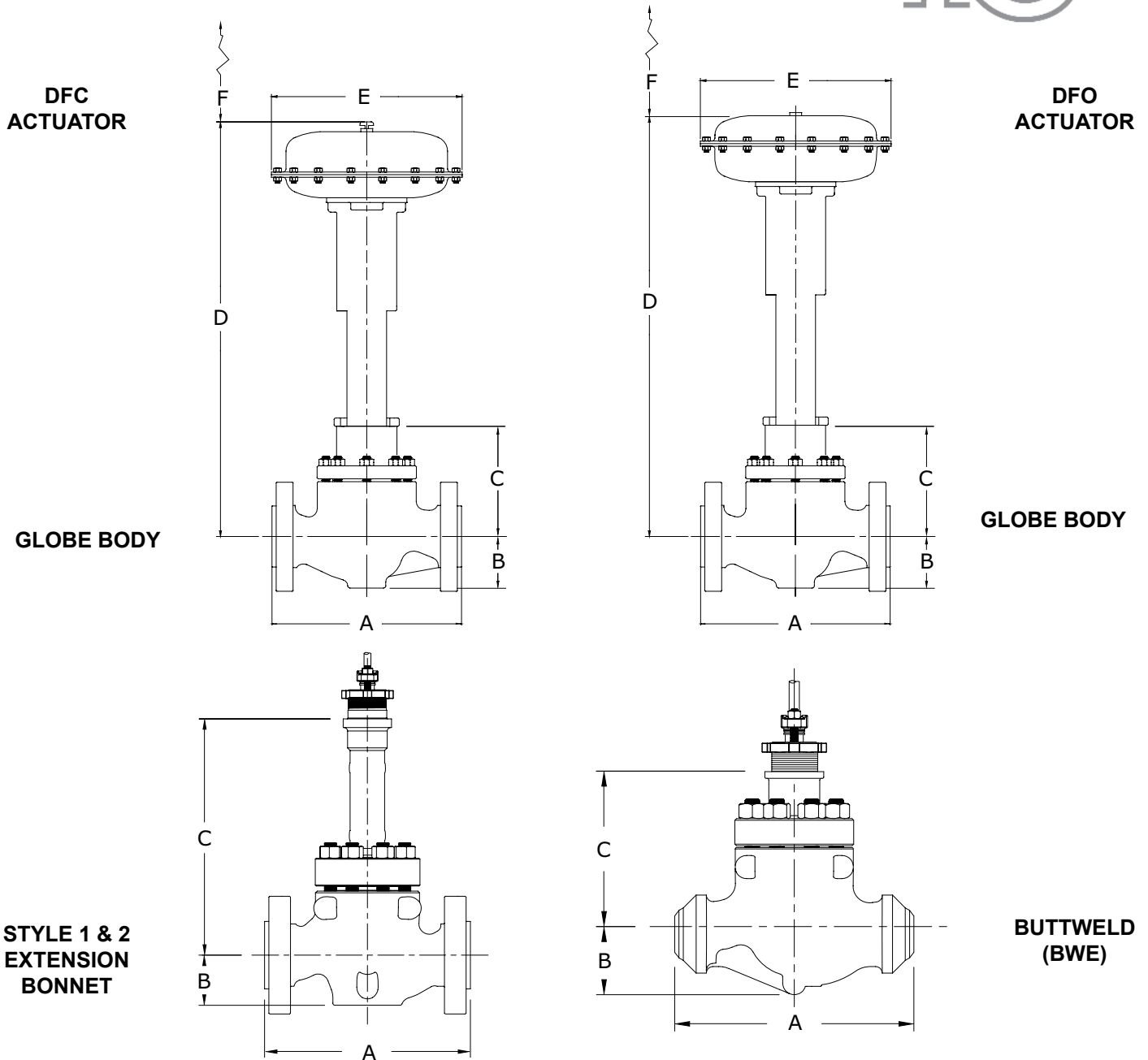

### F Dimension

1/2" to 2" Valve - 6.88" (175 mm)

Figure 2 Typical Valve Assembly Diagrams



# Model 363 Control Valves

## Technical Sales Bulletin

**Figure 3** Cross-section of 363 Series Control Valve with Trim Details

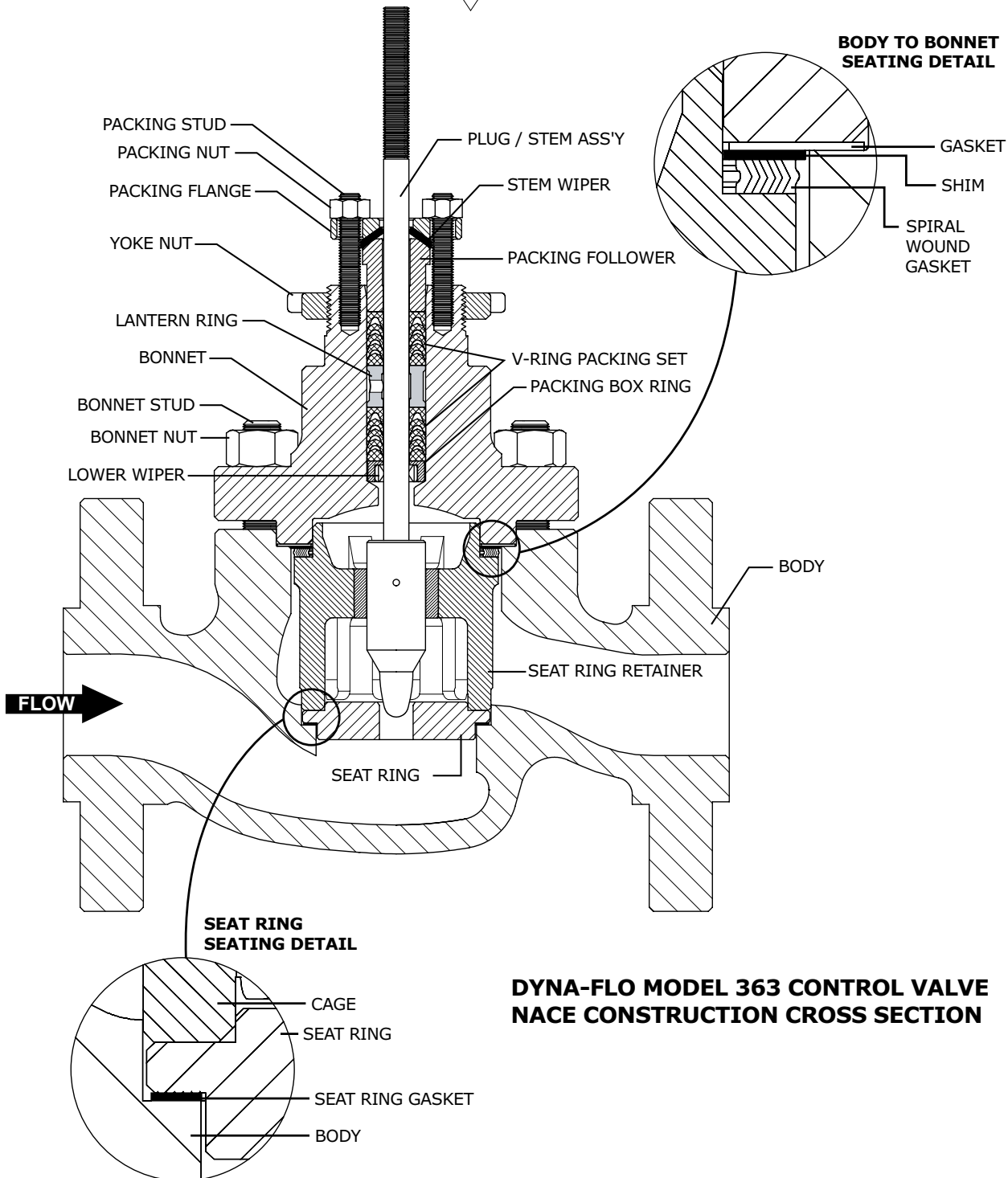

### DYNA-FLO MODEL 363 CONTROL VALVE NACE CONSTRUCTION CROSS SECTION

# Model 363 Control Valves

## Technical Sales Bulletin

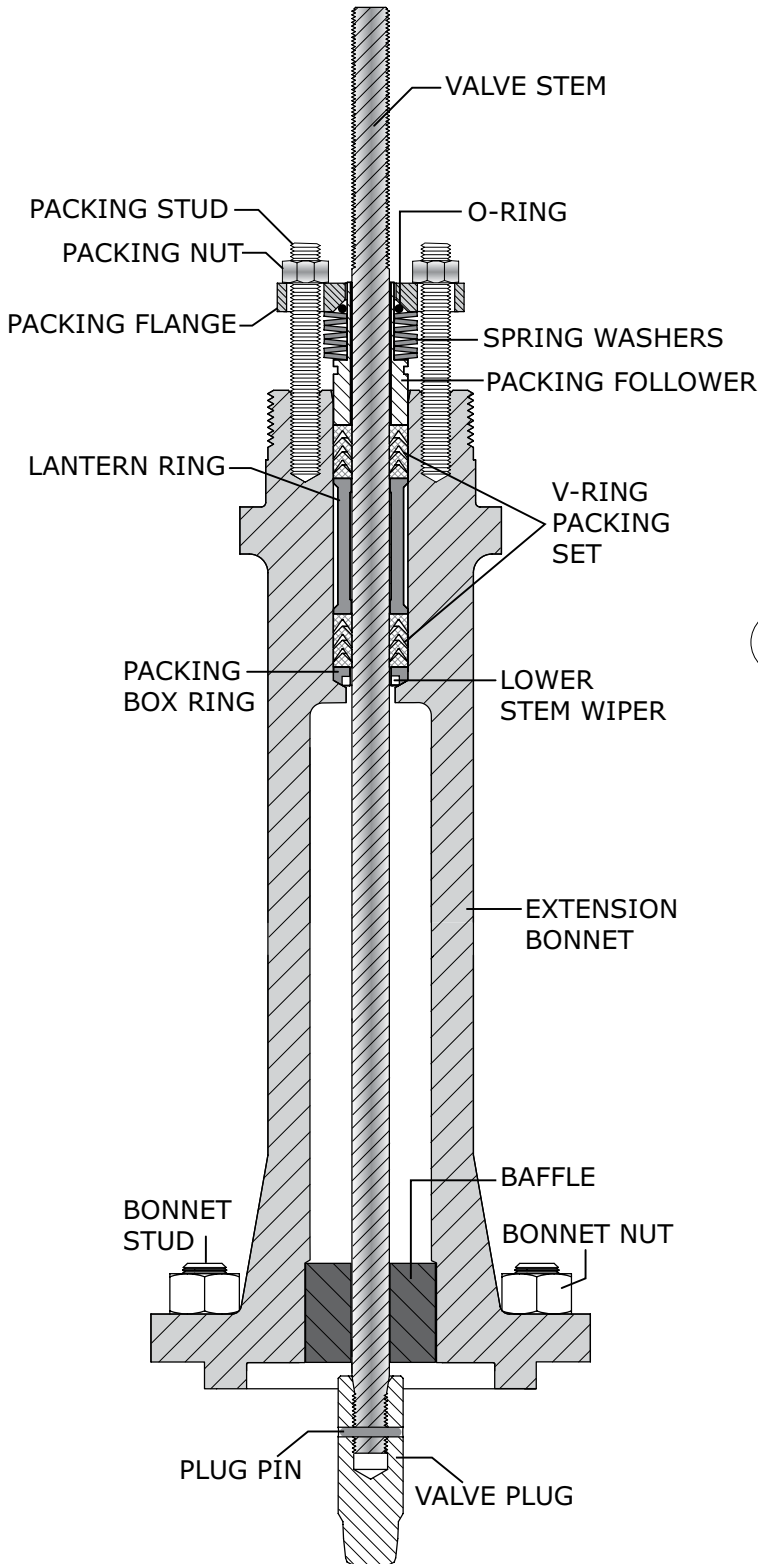

**Figure 4** Model 363 Extension Bonnet Cross Section

**Figure 5** Valve Plug Style Diagrams

\*NOTE - plug styles continued on Page 14.

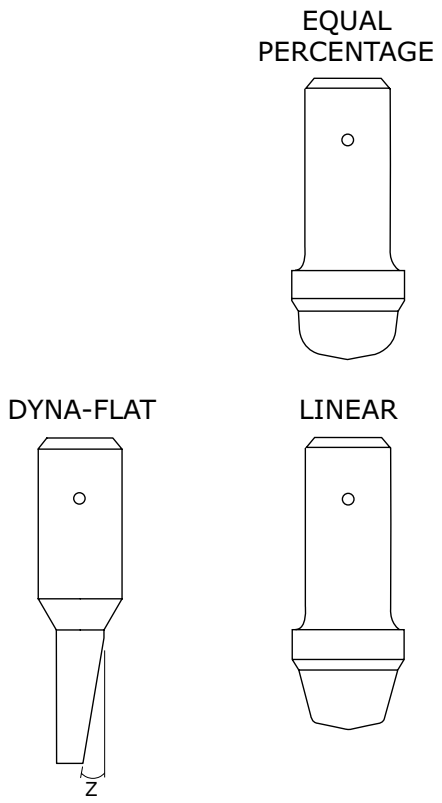



# Model 363 Control Valves

## Technical Sales Bulletin

**Figure 6** Model 363 Bellows Bonnet Cross Section

For Bellows Bonnet valves 150 - 300 Class maximum pressure is 300 Psig at 350°F.

**Figure 7** Valve Plug Style Diagrams

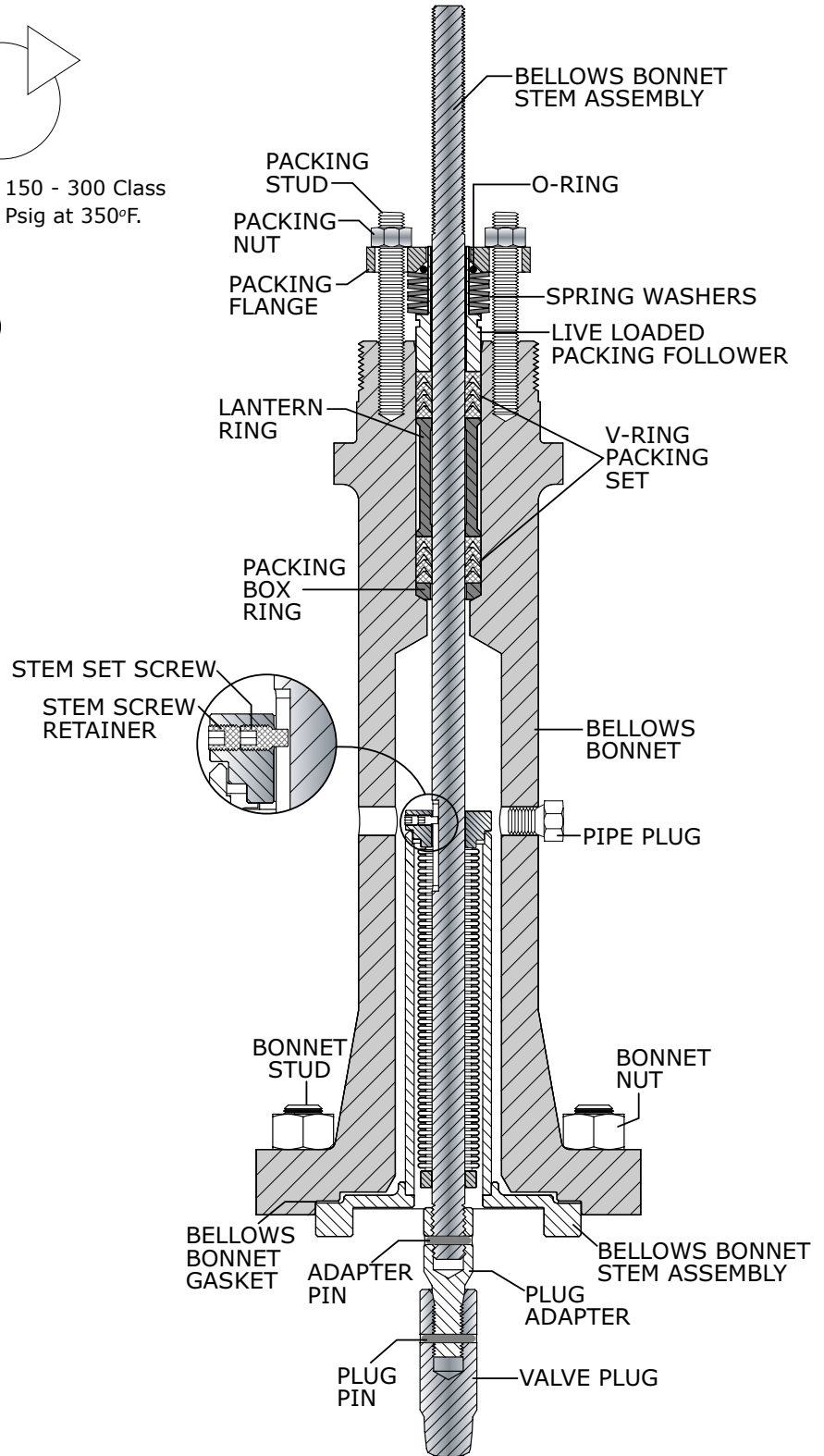
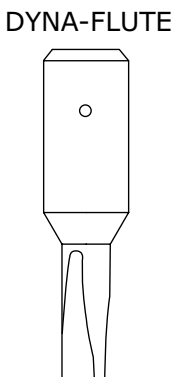
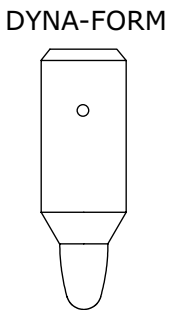
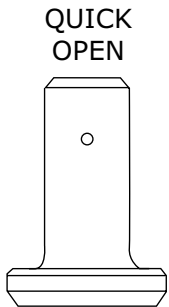

# Model 363 Control Valves

## Technical Sales Bulletin

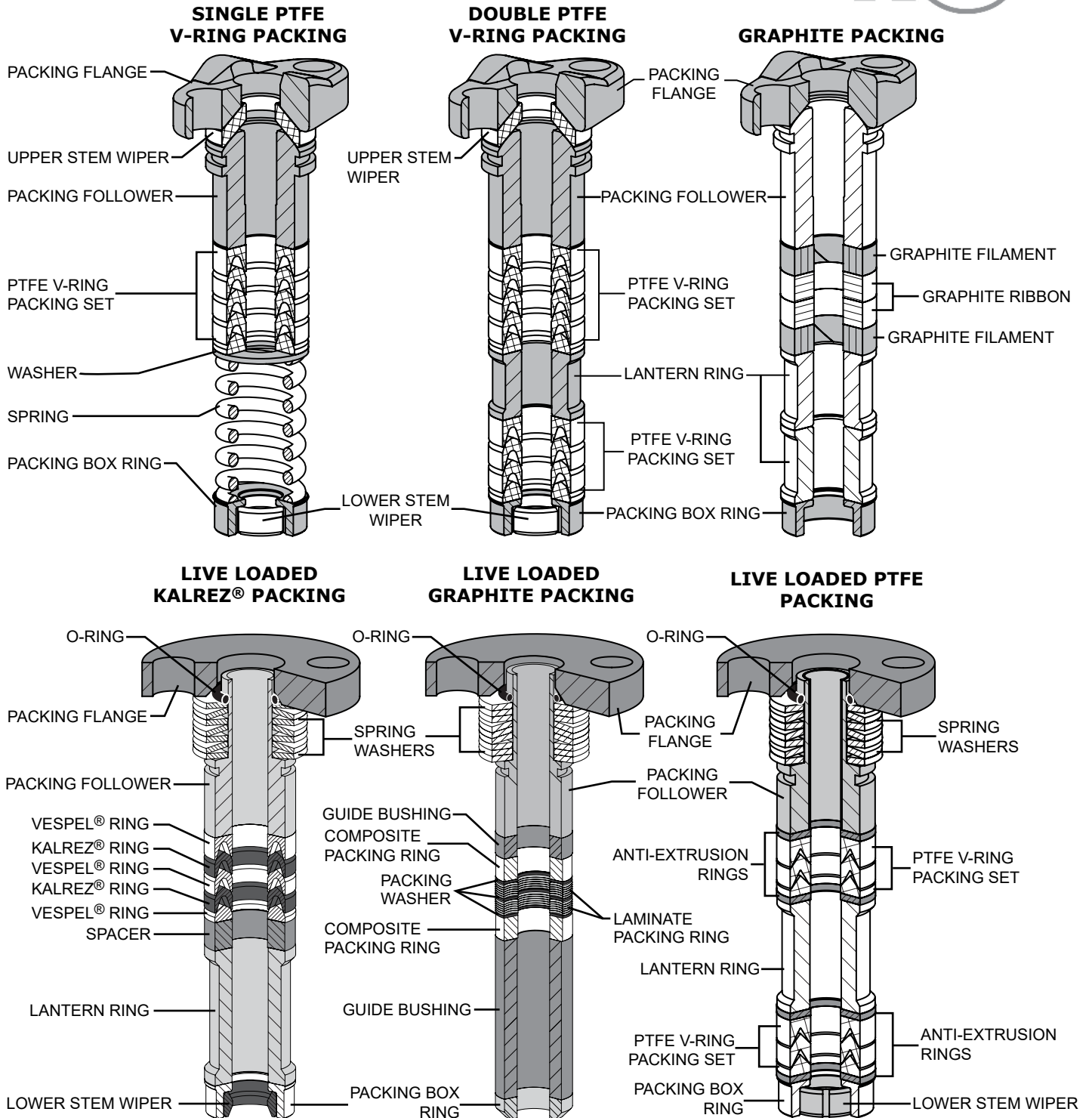

**Figure 8** Typical Packing Arrangements



# Model 363 Control Valves

## Technical Sales Bulletin

**Table 15**

### Common Valve Parts Typical Construction Materials and Temperature Limitations

Part	Material	Temperature Limitations			
		Min. °F	Max. °F	Min. °C	Max. °C
Valve Stem	S20910	NLF <sup>(1)</sup>	NLF <sup>(1)</sup>	NLF <sup>(1)</sup>	NLF <sup>(1)</sup>
Seat Ring / Bonnet / Cage Gaskets	S31600 <sup>(2)</sup> / Graphite	NLF <sup>(1)</sup>	NLF <sup>(1)(3)</sup>	NLF <sup>(1)</sup>	NLF <sup>(1)(3)</sup>
Spiral Wound Gaskets	N06600 / Graphite	NLF <sup>(1)</sup>	NLF <sup>(1)</sup>	NLF <sup>(1)</sup>	NLF <sup>(1)</sup>
Shim	S30400	NLF <sup>(1)</sup>	NLF <sup>(1)</sup>	NLF <sup>(1)</sup>	NLF <sup>(1)</sup>
Bellows Bonnet Gasket	S31600 <sup>(2)</sup> / Graphite	NLF <sup>(1)</sup>	NLF <sup>(1)(3)</sup>	NLF <sup>(1)</sup>	NLF <sup>(1)(3)</sup>
Bellows Assembly	S31600 <sup>(2)</sup> / N06625	Refer to Table 18.			

**NOTES:**

- 1 - NLF - This Material is Not A Limiting Factor. For the temperature limitation refer to the valve body material temperature limit.
- 2 - All S31600 barstock is dual grade S31600/S31603 (316/316L).
- 3 - Maximum temperature limited to 800°F (427°C) for oxidizing service.

**Table 16**

### Body to Bonnet Bolting Temperature Limitations

Body Material	ASME Class	Bolt/Nut Material	Temperature Limitations			
			Min. °F	Max. °F	Min. °C	Max. °C
LCC	150/300/600	B7/2H <sup>(1)(2)</sup>	-50	650	-46	343
		B7M/2HM <sup>(3)</sup>	-50	650	-46	343
WCC/WC9	150/300/600	B7/2H <sup>(1)(2)</sup>	-20	800	-29	427
		B7M/2HM <sup>(3)</sup>	-20	800	-29	427
CF8M	150/300/600	B7 Fluorokote #1 / 2H Fluorokote #1 (Standard) <sup>(2)</sup>	-50	500	-46	260
		B8M/8M <sup>(2)</sup>	-325	800	-198	427
		B7M Fluorokote #1/ 2HM Fluorokote #1 <sup>(3)</sup>	-50	500	-46	260

**NOTES:**

- 1 - Standard non-NACE option.
- 2 - NACE MR0175/ISO15156 Non-Exposed Bolting option (Bolting that is not directly exposed to sour environments and is not to be buried, insulated, equipped with flange protectors, or otherwise denied direct atmospheric exposure).
- 3 - NACE MR0175/ISO15156 Exposed Bolting option (Bolting that will be exposed directly to the sour environment or that will be buried, insulated, equipped with flange protectors, or otherwise denied direct atmospheric exposure).



# Model 363 Control Valves

## Technical Sales Bulletin



**Table 17**

<b>Bonnet and Packing Selection<sup>(1)</sup></b>		
<b>Bonnet Style</b>	<b>Packing Material</b>	<b>In-Body Process Temperature Limitations</b>
<b>Standard Bonnet:</b> Standard for valve sizes 1 through 6 inch.	PTFE V-Ring	0°F to 450°F (-18°C to 232°C)
	Graphite (Ribbon/Filament)	0°F to 1000°F (-18°C to 538°C) <sup>(2)</sup>
<b>Extension Bonnet Style 1:</b> Standard for 8 inch valves. Optional for valve sizes 1 through 6 inch.	PTFE V-Ring	-50°F to 800°F (-46°C to 427°C)
	Graphite (Ribbon/Filament)	-50°F to 1000°F (-46°C to 1000°C) <sup>(2)</sup>
<b>Extension Bonnet Style 2:</b> Optional for 1 through 8 inch valve sizes.	PTFE V-Ring	-150°F to 800°F (-101°C to 427°C)
	Graphite (Ribbon/Filament)	-150°F to 1000°F (-101°C to 538°C) <sup>(2)</sup>
<b>Bellows Bonnet</b>	PTFE V-Ring	Refer to Table 18.
	Graphite (Ribbon/Filament)	
<p><b>1</b> The above temperatures assume the presence of an ambient temperature outside the valve body of 70°F (21°C) with no bonnet insulation. An extension bonnet may be required when operating valves in low temperatures to prevent damage that could occur from the formation of valve stem frost. Other limiting factors, such as trim material components, will have to be considered. Refer to the Live Loaded Sliding Stem Packing Manual (Part Number P-LLPS) for Live Loaded packing temperature limitations.</p> <p><b>2</b> Maximum temperature limited to 700°F (371°C) for oxidizing service.</p>		
<p><b>NOTE:</b> For temperatures above or below these standard temperatures consult Dyna-Flo.</p>		

**Table 18**

<b>Bellows Bonnet Pressure/Temperature Rating</b>								
<b>Bellows Style</b>	<b>Pressure At</b>							
	100°F (38°C)	200°F (93°C)	300°F (149°C)	400°F (204°C)	500°F (260°C)	600°F (316°C)	700°F (371°C)	800°F (427°C)
<b>1 Ply</b>	550 Psig	506 Psig	479 Psig	451 Psig	429 Psig	413 Psig	402 Psig	396 Psig
	38 bar	35 bar	33 bar	31 bar	30 bar	29 bar	28 bar	27 bar
<b>2 Ply</b>	1000 Psig	920 Psig	870 Psig	820 Psig	780 Psig	750 Psig	730 Psig	720 Psig
	70 bar	63 bar	60 bar	57 bar	54 bar	52 bar	50 bar	50 bar



# Model 363 Control Valves

## Technical Sales Bulletin

**Table 19**

### Class VI Valve Shut-off Configurations

Valve Plug	Seat Ring Retainer	Seat Ring	Trim Temperature Limit
S31600 <sup>(1)</sup> / CoCr-A Hard Faced Seat with standard beveled seat	CF8M	S31600 <sup>(1)</sup> with Radiused Seat (Special Design)	Not a limiting factor
S31600 <sup>(1)</sup> / CoCr-A Hard Faced Seat and Guide with standard beveled seat	CF8M	S31600 <sup>(1)</sup> with Radiused Seat (Special Design)	Not a limiting factor
<b>NOTES:</b>			
<b>1</b> - All S31600 barstock is dual grade S31600/S31603 (316/316L).			

**Table 20**

### Trim Options

Trim Spec	Valve Plug	Stem	Retainer	Seat Ring	Guide Bushing
Z1	S41600	S20910	CF8M	S41600	S17400 DH1150
Z2	S31600 <sup>(1)</sup>	S20910	CF8M	S31600 <sup>(1)</sup>	S17400 DH1150
Z3	S31600 <sup>(1)</sup> / Alloy 6 Hard Faced Seat	S20910	CF8M	S31600 <sup>(1)</sup> / Alloy 6 Hard Faced Seat	S17400 DH1150
Z4	S31600 <sup>(1)</sup> / Alloy 6 Hard Faced Seat & Guide	S20910	CF8M	S31600 <sup>(1)</sup> / Alloy 6 Hard Faced Seat	Alloy 6 (R30006)
Z6	S31600 <sup>(1)</sup>	S20910	CF8M	S31600 <sup>(1)</sup>	Alloy 6 (R30006)
Z7	S31600 <sup>(1)</sup> / Alloy 6 Hard Faced Seat & Tip	S20910	CF8M	S31600 <sup>(1)</sup> / Alloy 6 Hard Faced Seat & Bore	—
Z8	S31600 <sup>(1)</sup> / Alloy 6 Hard Faced Seat & Guide	S20910	CF8M	S31600 <sup>(1)</sup> / Alloy 6 Hard Faced Seat	S17400 DH1150
Z9	S31600 <sup>(1)</sup> / Alloy 6 Hard Faced Seat	S20910	CF8M	S31600 <sup>(1)</sup>	S17400 DH1150
ZB	S31600 <sup>(1)</sup> / Alloy 6 Hard Faced Seat	S20910	CF8M	S31600 <sup>(1)</sup> / Alloy 6 Hard Faced Seat	Alloy 6 (R30006)
ZF	S41600	S20910	CF8M	S41600	—
ZN	S31600 <sup>(1)</sup> / Alloy 6 Hard Faced Seat & Tip	S20910	CF8M	S31600 <sup>(1)</sup>	—
ZR	S31600 <sup>(1)</sup> / Alloy 6 Hard Faced Seat & Tip	S20910	CF8M	S31600 <sup>(1)</sup> / Alloy 6 Hard Faced Seat	—

**NOTE:**

**1** - All S31600 barstock is dual grade S31600/S31603 (316/316L).

# Model 363 Control Valves

## Technical Sales Bulletin



Table 21

### Valve Body/Trim Option Temperature Limitations For Equal Percentage, Dyna-Form, Linear and Quick Opening Valve Plugs

Body Material	Body Size inch	Trim Designation	Temperature Limitations			
			Min. °F	Max. °F	Min. °C	Max. °C
LCC	All Sizes	Z1	-20	650	-29	343
		Z2	-50	650 <sup>(1)</sup>	-46	343 <sup>(1)</sup>
		Z3	-50	650 <sup>(1)</sup>	-46	343 <sup>(1)</sup>
		Z4	-50	500	-46	260
		Z6	-50	500 <sup>(1)</sup>	-46	260 <sup>(1)</sup>
		Z8 / Z9	-50	650	-46	343
CF8M	1/2 3/4 1 1-1/2	Z1	-20	670	-29	354
		Z2	-150	700 <sup>(1)</sup>	-101	371 <sup>(1)</sup>
		Z3	-150	700 <sup>(1)</sup>	-101	371 <sup>(1)</sup>
		Z4	-325	500	-198	260
		Z6	-325	500 <sup>(1)</sup>	-198	260 <sup>(1)</sup>
		Z8 / Z9	-150	700	-101	371
		ZB	-325	500 <sup>(1)</sup>	-198	60 <sup>(1)</sup>
	2	Z1	-20	550	-29	288
		Z2	-150	570 <sup>(1)</sup>	-101	299 <sup>(1)</sup>
		Z3	-150	570 <sup>(1)</sup>	-101	299 <sup>(1)</sup>
		Z4	-325	500	-198	260
		Z6	-325	500 <sup>(1)</sup>	-198	260 <sup>(1)</sup>
		Z8 / Z9	-150	570	-101	299
		ZB	-325	500 <sup>(1)</sup>	-198	260 <sup>(1)</sup>
WCC	All Sizes	Z1	-20	800	-29	427
		Z2, Z3	-20	800 <sup>(1)</sup>	-29	427 <sup>(1)</sup>
		Z4	-20	500	-29	260
		Z6	-20	500 <sup>(1)</sup>	-29	260 <sup>(1)</sup>
		Z8 / Z9	-20	800	-29	427
		ZB	-20	500 <sup>(1)</sup>	-29	260 <sup>(1)</sup>
WC9	All Sizes	Z1	-20	800	-29	427
		Z2	-20	800 <sup>(1)</sup>	-29	427 <sup>(1)</sup>
		Z3	-20	800 <sup>(1)</sup>	-29	427 <sup>(1)</sup>
		Z4	-20	500	-29	260
		Z6	-20	500 <sup>(1)</sup>	-29	260 <sup>(1)</sup>
		Z8 / Z9	-20	800	-29	427
		ZB	-20	500 <sup>(1)</sup>	-29	260 <sup>(1)</sup>

**NOTES:**

1 - Trim temperature limited to 300°F (149°C) when used with non-lubricating fluids.



# Model 363 Control Valves

## Technical Sales Bulletin

**Table 22**

**Valve Body/Trim Option Temperature Limitations  
For Dyna-Flute and Dyna-Flat Valve Plugs**

Body Material	Body Size inch	Trim Designation	Temperature Limitations			
			Min. °F	Max. °F	Min. °C	Max. °C
LCC	All Sizes	Z7	-50	800	-46	427
		ZF	-20	600	-29	316
		ZN	-50	300	-46	149
		ZR	-50	300	-46	149
CF8M	1/2 3/4 1 1-1/2	Z7	-325	1100	-198	593
		ZF	-20	600	-29	316
		ZN	-325	300	-198	149
		ZR	-150	300	-101	149
	2	Z7	-325	1100	-198	593
		ZF	-20	550	-29	288
		ZN	-325	300	-198	149
		ZR	-150	300	-101	149
WCC	All Sizes	Z7	-20	800	-29	427
		ZF	-20	600	-29	316
		ZN	-20	300	-29	149
		ZR	-20	300	-29	149
WC9	All Sizes	Z7	-20	1050 <sup>(1)</sup>	-29	565 <sup>(1)</sup>
		ZF	-20	600	-29	316
		ZN	-20	300	-29	149
		ZR	-20	300	-29	149

**NOTES:**

**1** - Maximum temperature is limited to 870°F (466°C) for 2 inch valves.

# Model 363 Control Valves

## Technical Sales Bulletin



**Table 23**

**Maximum Allowable Pressure Drops  
For Equal Percentage, Dyna-Form, Linear, and Quick Open Valve Plugs**

Trim Designation	Shutoff Pressure Drop		Flowing Pressure Drop	
	Psig	bar	Psid	bar
Z1	1,500	103	1,500	103
Z2	300 <sup>(1)</sup>	21 <sup>(1)</sup>	1,500	103
Z3	1,500	103	1,500	103
Z4	1,500	103	1,500	103
Z6	300 <sup>(1)</sup>	21 <sup>(1)</sup>	1,500	103
Z8	1,500	103	1,500	103
ZB	1,500	103	1,500	103
<b>NOTES:</b>	<b>1</b> - May be used up to 1500 Psig (103 bar) with clean dry gas.			

**Table 24**

**Maximum Allowable Pressure Drops  
For Dyna-Flute and Dyna-Flat Valve Plugs**

Trim Designation	Shutoff Pressure Drop		Flowing Pressure Drop	
	Psig	bar	Psid	bar
Z7	1,500	103	1,500	103
ZF	1,500	103	1,500	103
ZN	300 <sup>(1)</sup>	21 <sup>(1)</sup>	1,500	103
ZR	1,500	103	1,500	103
<b>NOTES:</b>	<b>1</b> - May be used up to 1500 Psig (103 bar) with clean dry gas.			



# Model 363 Control Valves

## Technical Sales Bulletin

**Table 25**

**Bellows Bonnet Estimated Cycle Life<sup>(1)</sup> at 150 Psig (10 bar) and 100°F (38°C)**

Valve Size inch	Bellows Style	Travel <sup>(2)</sup> inch (mm)					
		0.14 (3.6)	0.19 (4.6)	0.28 (6.4)	0.38 (9.7)	0.56 (14.2)	0.75 (19.1)
1/2 3/4 1 1-1/2	1 Ply	8,000,000 cycles	4,000,000 cycles	1,400,000 cycles	550,000 cycles	150,000 cycles	50,000 cycles
	2 Ply	10,000,000 cycles	10,000,000 cycles	2,300,000 cycles	800,000 cycles	160,000 cycles	50,000 cycles
2		0.21 (5.3)	0.28 (7.1)	0.42 (10.7)	0.56 (14.2)	0.88 (22.2)	1.12 (28.6)
	1 Ply	8,000,000 cycles	4,000,000 cycles	1,400,000 cycles	550,000 cycles	150,000 cycles	50,000 cycles
	2 Ply	10,000,000 cycles	10,000,000 cycles	2,300,000 cycles	800,000 cycles	160,000 cycles	50,000 cycles
<b>NOTES:</b>	<b>1</b> - The estimated cycle life does not take into account external environmental effects such as piping system vibration. <b>2</b> - For optimum cycle life, Bellows Bonnets are normally sold with the travel limited. Bellows Bonnets may operate at maximum travel but this will cause reduced cycle life.						

**Table 26**

**Bellows Bonnet Estimated Cycle Life<sup>(1)</sup> at Maximum Pressure and 600°F (316°C)**

Valve Size inch	Bellows Style	Travel <sup>(2)</sup> inch (mm)					
		0.14 (3.6)	0.19 (4.6)	0.28 (6.4)	0.38 (9.7)	0.56 (14.2)	0.75 (19.1)
1/2 3/4 1 1-1/2	1 Ply	100,000 cycles	80,000 cycles	50,000 cycles	30,000 cycles	12,000 cycles	7,000 cycles
	2 Ply	100,000 cycles	90,000 cycles	50,000 cycles	30,000 cycles	12,000 cycles	7,000 cycles
2		0.21 (5.3)	0.28 (7.1)	0.42 (10.7)	0.56 (14.2)	0.88 (22.2)	1.12 (28.6)
	1 Ply	100,000 cycles	80,000 cycles	50,000 cycles	30,000 cycles	12,000 cycles	7,000 cycles
	2 Ply	100,000 cycles	90,000 cycles	50,000 cycles	30,000 cycles	12,000 cycles	7,000 cycles
<b>NOTES:</b>	<b>1</b> - The estimated cycle life does not take into account external environmental effects such as piping system vibration. <b>2</b> - For optimum cycle life, Bellows Bonnets are normally sold with the travel limited. Bellows Bonnets may operate at maximum travel but this will cause reduced cycle life.						

# Model 363 Control Valves

## Technical Sales Bulletin



Table 27

**MAXIMUM SIZING COEFFICIENTS**  
**FULL PORT**  
**EQUAL PERCENTAGE CHARACTERISTIC**  
**GLOBE BODY VALVE**  
**FLOW UP**

Valve Size Inches	Port Inches (mm)	Travel Inches (mm)	Coefficient	Percentage of Valve Travel
				100%
1/2	1/2 (12.7)	3/4 (19.1)	C <sub>v</sub>	4.52
3/4	3/4 (19.1)	3/4 (19.1)	C <sub>v</sub>	8.35
1	1 (25.4)	3/4 (19.1)	C <sub>v</sub>	13.2
1-1/2	1-1/2 (38.1)	3/4 (19.1)	C <sub>v</sub>	28.1
2	2 (50.8)	1-1/8 (28.6)	C <sub>v</sub>	53.8

**NOTE:** For the complete list of sizing coefficients refer to catalogue P-CVSM.

Table 28

**BELLOWS BONNET SIZING COEFFICIENTS<sup>(1)</sup>**

Valve Size inch	Bellows Travel inch (mm)	C <sub>v</sub> - Full Port Trim			C <sub>v</sub> - Reduced Port Trim		
		Equal Percentage	Linear	Quick Opening	Equal Percentage	Linear	Quick Opening
1/2	0.56 (14.2)	-	-	4.44	-	-	-
3/4	0.56 (14.2)	-	-	9.72	-	-	-
1	0.56 (14.2)	9.15	11.6	16.8	-	-	-
1-1/2	0.56 (14.2)	13.1	27.5	33.6	10.0	12.0	19.0
2	0.88 (22.2) <sup>(2)</sup>	38.8	46.2	58.5	15.9	15.7	17.9

**NOTES:**  
**1** - Bellows Bonnet travel is 75% of the maximum rated valve travel.  
**2** - Bellows Travel for Reduced Port Trim is 0.75 inch (19.1 mm).

# Model 363 Control Valves

## Technical Sales Bulletin



### ***Our Commitment to Quality***

Dyna-Flo is committed to continuous improvement. While all efforts have been made to ensure the accuracy of the content in this document, modifications or improvements to the information, specifications, and designs may occur at any time without notice. This document was published for informational purposes only, and does not express or imply suitability, a warranty, or guarantee regarding the products or services described herein or their use or applicability.

Neither Dyna-Flo Control Valve Services Ltd., nor any of their affiliated entities assumes responsibility for the selection, use and maintenance of any product. Responsibility for selection, use and maintenance of any product remains with the purchaser and end-user.



# Model 363 Control Valves

## Technical Sales Bulletin



This page left intentionally blank.



# Model 363 Control Valves

## MODEL NUMBERING SYSTEM

SAMPLE PART NUMBER: 363-2AFL-108P2-ES4

VALVE SIZE					2				
9	1/2 INCH	7	3/4 INCH	1		1 INCH	5	1-1/2 INCH	
2	2 INCH								
ASME RATING					A				
A	150	B	300	C		600			
END CONNECTION					F				
F	RF	J	RTJ	N		NPT	T	BWE SCH 40	
L	BWE SCH 80	S	SOCKET WELD						
BODY MATERIAL					L				
L	LCC	W	WCC	M		CF8M	9	WC9	
BOLTING					-				
-	B7 / 2H (STANDARD)			A		B7M / 2HM			
B	B8M / 8M			K		B7 / 2H FLUOROKOTE #1			
L	B7M / 2HM FLUOROKOTE #1								
TRIM					1				
1	TRIM Z1	2	TRIM Z2	3		TRIM Z3	4	TRIM Z4	
6	TRIM Z6	7	TRIM Z7	8		TRIM Z8	9	TRIM Z9	
B	TRIM ZB	F	TRIM ZF	N		TRIM ZN	R	TRIM ZR	
PORT SIZE					08				
01	3/16 INCH PORT	02	1/4 INCH PORT	03		3/8 INCH PORT	04	1/2 INCH PORT	
06	3/4 INCH PORT	08	1 INCH PORT	12	1-1/2 INCH PORT	16	2 INCH PORT		
PACKING STYLE					P				
P	SINGLE PTFE V-RING (PRESSURE)			J		DOUBLE PTFE V-RING (PRESSURE)			
G	SINGLE GRAPHITE (PRESSURE)			V		DOUBLE PTFE V-RING (VACUUM)			
R	DOUBLE PTFE V-RING (VACUUM / PRESSURE)			L		LIVE LOADED PTFE V-RING (PRESSURE)			
T	LIVE LOADED GRAPHITE (PRESSURE)			D		LIVE LOADED DUPLEX (PRESSURE)			
K	LIVE LOADED KALREZ®								
YOKE BOSS SIZE					2				
1	2-1/8" (3/8" STEM)		2	2-13/16" (1/2" STEM)		3	3-9/16" (3/4" STEM)		
PAINT					-				
-	DFPS-01 (STANDARD)			2		DFPS-02 (SEVERE SERVICE)			
3	DFPS-03 (HIGH TEMPERATURE)								
CHARACTERISTIC					E				
E	EQUAL PERCENT (FULL PORT)			Q		QUICK OPENING (FULL PORT)			
L	LINEAR (FULL PORT)			M		DYNA-FORM			
G	DYNA-FLUTE - 1 FLUTE			F		DYNA-FLUTE - 3 FLUTE			
D	DYNA-FLAT (1D)			C		DYNA-FLAT (1D 8M)			
A	DYNA-FLAT (1D 55M)			H		DYNA-FLAT (3D25M)			
BONNET STYLE					S				
S	STANDARD			T		STANDARD TAPPED			
E	EXTENSION STYLE 1			H		EXTENSION STYLE 2			
B	BELLOWS SEAL								
SHUT-OFF CLASS					4				
4	CLASS IV	5	CLASS V	6		CLASS VI			

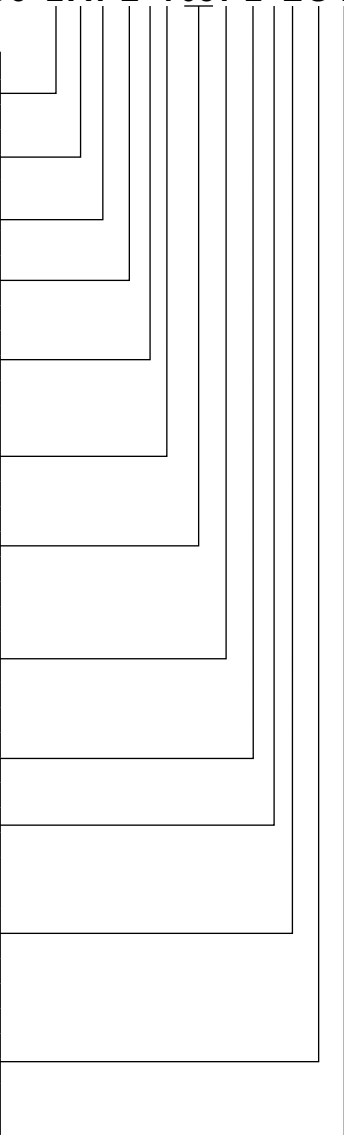

363