



an Accudyne Industries brand



MacRoy[®] G Pump

IOM Manual

Manual No : 53873

Rev. : 00

Rev. Date : 08/2015



an Accudyne Industries brand

PRECAUTIONS

For Pumps with PVC & 316SS Liquid Ends

WHEN USED IN SWIMMING POOLS OR SPAS / HOT TUBS (ANSI / NSF 50)

Caution on Chemical Concentration:



There is a potential for elevated chemical concentration during periods of no flow, for example, during backwash in the system. Steps, such as turning the pump off, should be taken during operation or installation to prevent this. Contact your sales representative or distributor about other external control options to help mitigate this risk.

Flow Indicating Device:



To ensure operation of the pump it is recommended that some type of Flow Indicating Device be installed to measure water flow rates and be appropriate for the output of the pump. Contact your distributor or sales representative for further information.

Head Loss / Over Pressure Protection / Back Pressure-Anti-Siphon Valve:



- Milton Roy metering pumps are positive displacement. Head loss is not applicable to the pump.
- To ensure safe operation of the pump it is recommended that some type of safety / pressure relief valve be installed to protect the piping and other system components from failing due to excessive pressure.
- If you are pumping downhill or into low or no system pressure, a back pressure / anti-siphon device should be installed to prevent over pumping or siphoning. Contact your distributor or sales representative for further information.

Additional Operation and Installation Instructions for 316SS or PVC Liquid Ends:



- Application of this pump to swimming pool / spas only evaluated to NSF / ANSI 50.
- There is a potential for elevated chemical concentration during periods of no flow, for example, during backwash in the system. Steps, such as turning the pump off, should be taken during operation or installation to prevent this. See your sales representative or distributor about other external control options to help mitigate this risk.
- Liquid Compatibility CAUTION: Determine if the materials of construction included in the liquid handling portion of your pump are adequate for the solution (chemical) to be pumped. ALWAYS wear protective clothing, face shield, safety glasses and gloves when working on or near your metering pump. Additional precautions should be taken depending on the solution being pumped. Refer to MSDS precautions from your solution supplier. Reference a Milton Roy Material Selection Chart for aid in selecting appropriate material of construction for fluids of your specific metering pump. Contact your sales representative or distributor for further information.

THIS PAGE INTENTIONALLY LEFT BLANK



TABLE OF CONTENTS

SECTION 1 - DESCRIPTION	7
1.1 GENERAL INFORMATION	7
1.2 PRINCIPLE OF OPERATION	7
1.3 GENERAL SPECIFICATIONS	8
1.4 PRODUCT CODE	10
SECTION 2 - INSTALLATION	11
2.1 UNPACKING	11
2.2 SAFETY PRECAUTIONS	11
2.3 STORAGE	11
2.4 MOUNTING	12
2.5 PIPING	12
2.6 LEAK DETECTION	16
2.7 ELECTRICAL CONNECTIONS	16
SECTION 3 - OPERATION	17
3.1 INITIAL START-UP	17
SECTION 4 - MAINTENANCE	19
4.1 SPARE PARTS	19
4.2 SHIPPING PUMPS FOR REPAIR	19
4.3 PREVENTIVE MAINTENANCE	20
4.4 CORRECTIVE MAINTENANCE	21
4.4.1 Check Valve Replacement	21
4.4.1.1 Plastic Check Valves (PVC, PVDF, POLY, & H ₂ SO ₄)	21
4.4.1.2 Models G6 & G7 Liquid End - Stainless Steel Check Valves (PVC, PVDF, POLY, & H ₂ SO ₄)	22
4.4.1.3 Model G5 Liquid End - Stainless Steel Check Valves (PVC, PVDF, POLY, & H ₂ SO ₄)	23
4.4.1.4 Model G5 Liquid End - Slurry Check Valves	23
4.4.1.5 Models G6 & G7 Liquid End - Slurry Check Valves	24
4.4.1.6 Models G5, G6 & G7 Liquid End - Polymer Check Valves	24
4.4.2 Diaphragm Replacement	25
4.4.2.1 Diaphragm Removal (All types; Refer to Figures 6-12)	25
4.4.2.2 Disassembly (Only Those Units With a "Hex Head" Diaphragm Cap Design)	25
4.4.2.3 Reassembly	25
4.4.2.4 Reinstallation of Assembly (Refer to Figures 6 Through 12)	25
4.4.3 Replacing Oil Seal	26
SECTION 5 - TROUBLESHOOTING GUIDE	28

SECTION 6 - PARTS **29**

6.1 GENERAL 29

6.2 ILLUSTRATED PARTS LIST 29

6.3 DRIVE, SIDE VIEW 31

6.4 DRIVE, TOP VIEW 34

6.5 G5 PLASTIC LIQUID END 37

6.6 G5 METALLIC LIQUID END - STAINLESS STEEL - NPT 40

6.7 G6 PLASTIC LIQUID END 42

6.8 G6 METALLIC LIQUID END - STAINLESS STEEL - NPT 45

6.9 G7 PLASTIC LIQUID END 47

6.10 G7 METALLIC LIQUID END - STAINLESS STEEL - NPT 50

6.11 CHECK VALVE PARTS 53

6.12 LEAK DETECTION PARTS 58

LIST OF ILLUSTRATIONS

FIGURE 1. Model / Product Code 9

FIGURE 2. Sample Nameplate 10

FIGURE 3. Mounting Hole Dimensions 12

FIGURE 4. Typical Recommended Pump Installation Scheme 13

FIGURE 5. Suction Lift Installation 14

FIGURE 6A. MacRoy® G Drive Parts - Side View (DWG 102-1999-0001) 30

FIGURE 6B. MacRoy® G Basic Parts - Top View (DWG 102-1999-0001) 33

FIGURE 7. G5 Plastic Liquid End (DWG 102-1999-007) 36

FIGURE 8. G5 Metallic Liquid End (DWG 102-1999-0008) 39

FIGURE 9. G6 Plastic Liquid End (DWG 102-1999-0009) 41

FIGURE 10. G6 Metallic Liquid End (DWG 102-1999-010) 44

FIGURE 11. G7 Plastic Liquid End (DWG 102-1999-011) 46

FIGURE 12. G7 Metallic Liquid End (DWG 102-1999-012) 49

FIGURE 13A. Model G5 Plastic Check Valve Parts (Item Number 425) 51

FIGURE 13B. Model G5 Metallic Check Valve Parts (Item Number 425) 51

FIGURE 13C. Model G6 & G7 Plastic Check Valve Parts (Item Number 425) 51

FIGURE 13D. Model G6 & G7 Metallic Check Valve Parts (Item Number 425) 51

FIGURE 13E. Model G5 Slurry Check Valve Parts (Item Number 425) 52

FIGURE 13F. Model G5, G6, and G7 Polymer Check Valve Parts (Item Number 425) 52

FIGURE 13G. Model G6 & G7 Slurry Check Valve Parts (Item Number 425) 52

FIGURE 14. Leak Detection, Switch and Gauge (Optional) (DWG 10219990004) 57

1.1 GENERAL INFORMATION

The MacRoy® G is a reciprocating, chemical dosing pump capable of producing controlled flows up to 310 gallons per hour (1175 L/H) at pressures up to 150 psi (10 BAR) (depending on the model). These pumps feature a mechanically actuated diaphragm liquid end, which eliminates the need for flow restricting contour plates, and a stroke adjustment mechanism based on the variable eccentric principle instead of the traditional lost motion design. This design substantially reduces pressure and flow pulsations contributing to an increase in the life of system components and more continuous chemical injection. It is designed for industrial service and offers an accuracy of $\pm 2\%$ of 100% rated flow between 10% and 100% of its flow range.

1.2 PRINCIPLES OF OPERATION

The pump consists of two major assemblies; the drive and the liquid end. Pump delivery is a function of the drive's stroke rate, liquid end size and stroke length. Stroke length can be adjusted while the pump is running or stopped by turning the stroke adjusting knob.

The drive motor transmits rotary motion to a worm gear speed reduction unit which in turn drives the variable eccentric crank. The adjustable crank imparts reciprocating motion to the diaphragm through an interposing connecting rod. The stroke length is adjusted by changing the position of the variable eccentric crank in the connecting rod assembly.

As the diaphragm starts back on the suction stroke, the pressure immediately drops inside the liquid end. When the liquid end pressure drops below the suction line pressure, the suction ball check is "pushed" upward and the process fluid in the suction line flows into the liquid end chamber. When the suction stroke ends, the diaphragm movement momentarily stops. The pressure in the liquid end equalizes with the pressure in the suction line and the suction ball check seats.

NOTE:

It is important that the pressure in the liquid end remain above the vapor pressure of the process fluid during the suction stroke. If the fluid pressure drops below the vapor pressure, cavitation will occur, negatively impacting the performance of the pump. If you suspect the possibility of cavitation, contact your Milton Roy Representative for assistance.

As the diaphragm starts forward on the discharge stroke the pressure immediately rises inside the liquid end. When the liquid end pressure rises above the discharge line pressure, the discharge ball check is "pushed" upward and the process fluid in the liquid end flows into the discharge line. When the discharge stroke ends, the diaphragm momentarily stops again. The pressure in the liquid end equalizes with the discharge line pressure and the discharge ball check reset. The cycle then starts again.

SECTION 1 - GENERAL DESCRIPTION

1.3 GENERAL SPECIFICATIONS

FLOW RATE	Up to 310 GPH (1175 L/H)
PRESSURE	Up to 150 PSI (10 BAR)
DESIGN	Mechanically Actuated Diaphragm
DRIVE	Variable Eccentric
ACCURACY	±2% of 100% rated flow between 10% & 100% of rated flow
ADJUSTMENT	Lockable micrometer is adjustable from 0% to 100% while pump is running or stopped
LUBRICATION	Oil bath Over 50°F (10°C), Zurn EP 95, 3 1/2 qt.(3.3 liter). Below 50°F (10°C), Zurn EP 35
WEIGHT	90 lb (40.8kg) Without EEC 109 lb (49.4 kg) With EEC
TEMPERATURE	Ambient and Liquid: 122°F (50°C) Maximum 14°F (-10°C) Minimum
SUCTION LIFT	8.2 ft. (2.5 meters) of water column maximum. 11 psi minimum internal pressure (4 psi maximum vacuum)
PAINT	Powder Coating
FLOW RATE AND PRESSURE CAPACITIES	Refer to Milton Roy Product Bulletin No. PD 3212 for specific details

ROUTINE MAINTENANCE KITS (RPM) MacRoy® G

Liquid End	Liquid End Material	Kit Number
GB40	POLYPRO	RPM019
	PVC	RPM022
	PVDF	RPM025
	316SS	RPM028
GB60	POLYPRO	RPM020
	PVC	RPM023
	PVDF	RPM026
	316SS	RPM029
GB80	POLYPRO	RPM021
	PVC	RPM024
	PVDF	RPM027
	316SS	RPM030

Liquid End	Liquid End Material	Kit Number
5	PP / PVC / ACRYLIC	RPM045
	PVDF	RPM046
	316SS	RPM047
	H2SO4 NPT CONN.	RPM175
	POLYMER	RPM126
	SLURRY	RPM400
6	PP / PVC / ACRYLIC	RPM048
	PVDF	RPM049
	316SS	RPM050
	H2SO4 NPT CONN.	RPM194
	POLYMER	RPM176
	SLURRY	RPM219
7	PP / PVC / ACRYLIC	RPM051
	PVDF	RPM052
	316SS	RPM053
	H2SO4 NPT CONN.	RPM203
	POLYMER	RPM221
	SLURRY	RPM220

SECTION 1 - GENERAL DESCRIPTION

1.4 PRODUCT CODE

MacRoy® G pumps are available in a variety of different configurations. For a breakdown of the options included in a specific pump, compare the pump model number and product code found on the pump nameplate with the model / product code breakdown shown in *Figure 1*. A sample nameplate is shown in *Figure 2*.

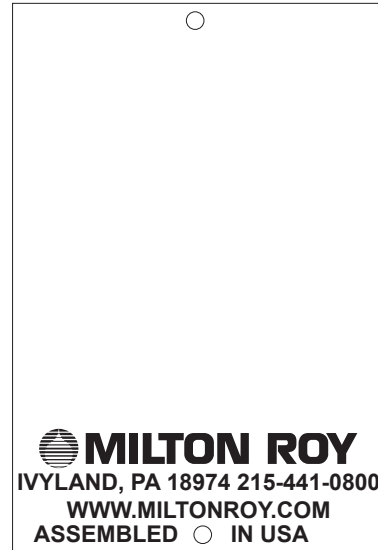

Figure 2. Sample Nameplate

Flow Rate / Maximum Pressure Table & RPM Kits

English Units

Liquid End Codes	SPM @		GPH @ Max Pressure		Max PSI
	60 Hz	50 Hz	60 Hz	50 Hz	
5	43	36	26	22	150
	86	72	53	44	
	120	102	75	63	
	173	144	106	88	
	-	180	-	110	
6	43	36	36	30	100
	86	72	73	61	
	120	102	104	87	
	173	144	147	123	
	-	180	-	154	
7	43	36	75	63	50
	86	72	149	124	
	120	102	208	173	
	173	144	300	250	
	-	180	-	312	

Metric Units

Liquid End Codes	SPM @		LPH @ Max Pressure		Max Bar
	60 Hz	50 Hz	60 Hz	50 Hz	
5	43	36	98	82	10
	86	72	200	167	
	120	102	284	237	
	173	144	400	334	
	-	180	-	416	
6	43	36	136	114	7
	86	72	276	230	
	120	102	394	328	
	173	144	556	464	
	-	180	-	583	
7	43	36	284	237	3.5
	86	72	564	470	
	120	102	787	656	
	173	144	1136	946	
	-	180	-	1181	

2.1 UNPACKING

Pumps are shipped Free On Board (FOB) factory or representative warehouse and the title passes to the customer when the carrier signs for receipt of the pump. In the event that damages occur during shipment, it is the responsibility of the customer to notify the carrier immediately and to file a damage claim.

Carefully examine the shipping crate upon receipt from the carrier to be sure there is no obvious damage to the contents. Open the crate carefully so accessory items fastened to the inside of the crate will not be damaged or lost. Examine all material inside the crate and check against packing list to be sure that all items are accounted for and intact.

2.2 SAFETY PRECAUTIONS

▲ WARNING WHEN INSTALLING, OPERATING, AND MAINTAINING THE MACROY® G PUMP, KEEP SAFETY CONSIDERATIONS FOREMOST. USE PROPER TOOLS, PROTECTIVE CLOTHING, AND EYE PROTECTION WHEN WORKING ON THE EQUIPMENT AND INSTALL THE EQUIPMENT WITH A VIEW TOWARD ENSURING SAFE OPERATION. FOLLOW THE INSTRUCTIONS IN THIS MANUAL AND TAKE ADDITIONAL SAFETY MEASURES APPROPRIATE TO THE LIQUID BEING PUMPED. BE EXTREMELY CAREFUL IN THE PRESENCE OF HAZARDOUS SUBSTANCES (E.G, CORROSIVES, TOXINS, SOLVENTS, ACIDS, CAUSTICS, FLAMMABLES AND ETC.).

▲ CAUTION THE PERSONNEL RESPONSIBLE FOR INSTALLATION, OPERATION AND MAINTENANCE OF THIS EQUIPMENT MUST BECOME FULLY ACQUAINTED WITH THE CONTENTS OF THIS MANUAL.

▲ CAUTION ANY SERVICING OF THIS EQUIPMENT MUST BE CARRIED OUT WHEN THE UNIT IS STOPPED AND ALL PRESSURE HAS BEEN BLED FROM THE LIQUID END. SHUT-OFF VALVES IN SUCTION AND DISCHARGE SIDES OF THE LIQUID END SHOULD BE CLOSED WHILE THE UNIT IS BEING SERVICED. ACTIONS SHOULD BE TAKEN TO ELIMINATE THE POSSIBILITY OF ACCIDENTAL START-UP WHILE SERVICING IS TAKING PLACE. A NOTICE SHOULD BE POSTED BY THE POWER SWITCH TO WARN THAT SERVICING IS BEING CARRIED OUT ON THE EQUIPMENT. SWITCH OFF THE POWER SUPPLY AS SOON AS ANY FAULT IS DETECTED DURING OPERATION (EXAMPLES: ABNORMALLY HIGH DRIVE TEMPERATURE, UNUSUAL NOISE AND DIAPHRAGM FAILURE).

2.3 STORAGE

Short Term Storage (Less than 6 Months)

It is preferable to store the material under a shelter in its original package to protect it from adverse weather conditions. In condensing atmospheres, follow the long term storage procedure.

Long Term Storage (Longer than 6 Months)

The primary consideration in storage of pump equipment is to prevent corrosion of external and internal components. This corrosion is caused by natural circulation of air as temperature of the surroundings change from day to night, day to day, and from season to season. It is not practical to prevent this circulation which carries water vapor and other corrosive gasses, so it is necessary to protect internal and external surfaces from their effects to the extent possible.

When the instructions given in this section are completed, the equipment is to be stored, sheltered and protected from direct exposure to weather.

The prepared equipment should be covered with a plastic sheet or a tarpaulin, but in a manner which will allow air circulation and prevent capture of moisture. Equipment should be stored 12 inches or more above the ground.

If equipment is to be shipped directly from Milton Roy into long term storage, contact Milton Roy to arrange for factory preparation.

SECTION 2 - INSTALLATION

Pump Drive

1. Flood the gearbox compartment with a high grade lubricating oil / rust preventative such as Mobile Oil Corporation product "Mobilarna 524". Fill the compartment completely to minimize air space and water vapor condensation. After storage, drain this material and refill the equipment with the recommended lubricant for equipment commissioning.
2. Remove drive motor and liquid end, and brush all unpainted metal surfaces with multipurpose grease (NLGI grade 2 or 3). Store these unattached.

Electrical Equipment

1. Motors should be prepared in the manner prescribed by their manufacturer. If information is not available, dismount and store motors as indicated in step 3 below.
2. Dismount electrical equipment (including motors) from the pump.
3. For all electrical equipment, place packets of Vapor Phase Corrosion Inhibitor (VPCI) inside of the enclosure, then place the entire enclosure, with additional packets, inside a plastic bag. Seal the bag tightly closed. Contact Milton Roy Service Department for recommended VPCI materials.

2.4 MOUNTING

CAUTION TO AVOID POSSIBLE DAMAGE TO EITHER PUMP OR PERSONNEL, BOLT PUMP DOWN AS SOON AS IT IS IN POSITION.

Support the pump firmly in a level position on a solid, vibration-free foundation, preferably with the base above floor level to protect the pump from wash downs and to provide easier access for service. Be sure to allow enough space around the pump for easy access during maintenance operations, pump adjustments, and / or oil filling or draining procedures.

MacRoy® G pumps are provided with mounting holes to accommodate anchor bolts. Refer to *Figure 3* for mounting hole dimensions.

Some MacRoy® G pumps are shipped with motors dismounted. After anchoring pump in position, install motor, referring to *Figure 6, Sheet 1*.

Make sure spring (360) provided with pump is installed in worm shaft prior to motor installation.

Pumps installed outdoors should be protected by a shelter.

2.5 PIPING

NPSH Considerations

Size piping to accommodate peak instantaneous flow. Because of the reciprocating motion of the pump diaphragm, pump delivery follows an approximate sine curve with a peak instantaneous flow pi (3.14) times the average flow. Therefore, piping must be designed for a flow 3.14 times the pump capacity; this means that a pump rated for 88 gallons per hour (333.1 L/hr.) requires piping sufficient for 3.14 x 88 gph, or 276 gph (1044.7 L/hr.).

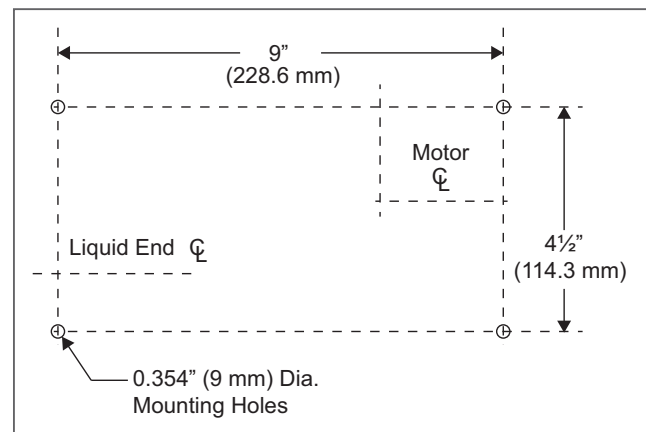

Figure 3. Mounting Hole Dimensions

SECTION 2 - INSTALLATION

To minimize viscous flow losses when handling viscous liquids, it may be necessary to use suction piping up to four times larger than the size of the suction connection on the pump. If in doubt, contact your nearest Milton Roy representative to determine the necessary pipe size.

General Piping Considerations

- Use extreme care in piping to plastic liquid end pumps with rigid pipe such as PVC. If excessive stresses or vibration is unavoidable, flexible connections are recommended.
- Use piping materials that will resist corrosion by the liquid being pumped. Use care in selecting materials to avoid galvanic corrosion at pump liquid end connections.
- Use piping heavy enough to withstand maximum pressures.
- Remove burrs, sharp edges and debris from inside piping. Blow out all pipe lines before making final connections to pump.
- Because vapor in the liquid end will cause inaccurate pump delivery, piping should be sloped to prevent vapor pockets
- When pumping suspended solids (such as slurries), install plugged crosses at all 90° line turns to permit line cleaning without dismantling piping.
- See Figure 4 for a typical recommended pump installation scheme.

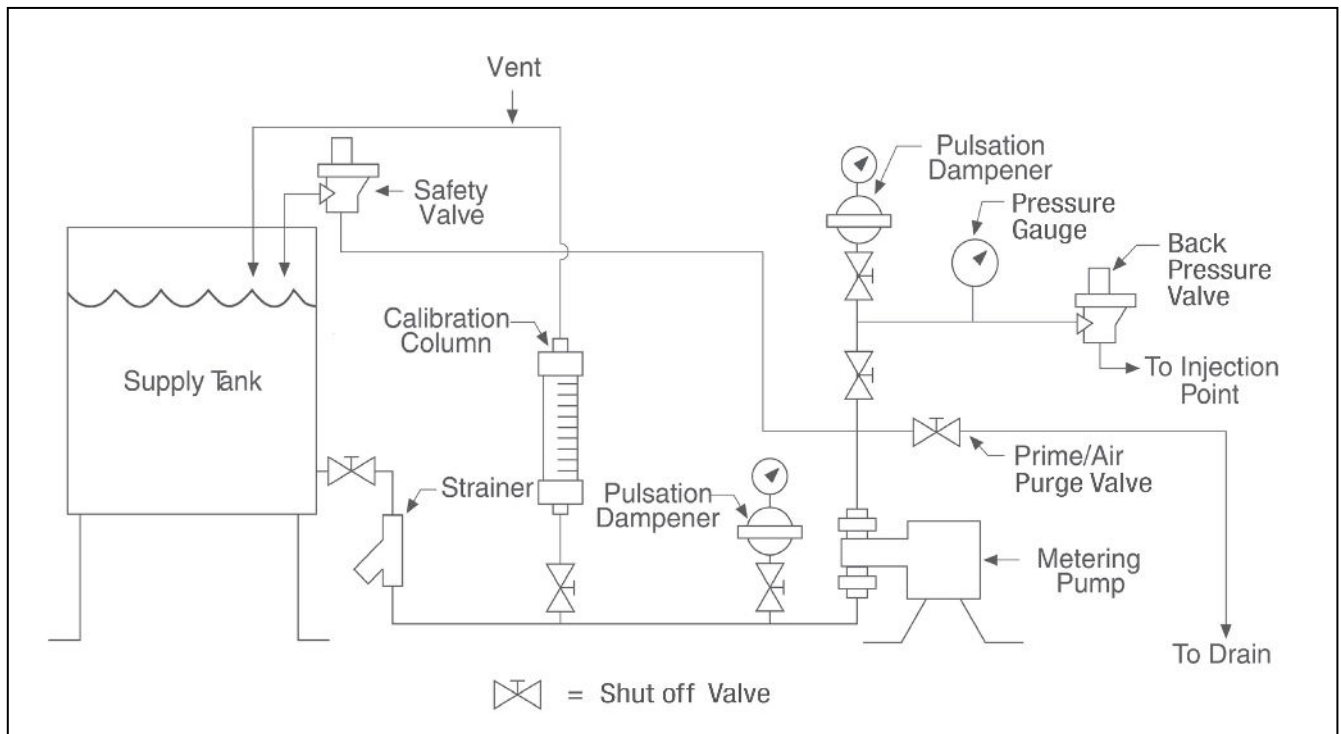

Figure 4. Typical Recommended Pump Installation Scheme

SECTION 2 - INSTALLATION

Suction Piping Considerations

- It is preferable to have the suction of the pump flooded by locating the liquid end below the lowest level of the liquid in the supply tank. Installing the supply vessel on the suction line close to the pump can help ensure a flooded suction line. (Consult Milton Roy for assistance in such applications.)
 - Avoid negative suction pressure conditions (suction lift), as such conditions adversely affect metering accuracy. A lift of 8.2 feet (2.5 meters) of water column is the maximum suction lift permissible.
 - MacRoy® G pumps are designed to operate with process liquid supplied at or above atmospheric pressure. Although these pumps can move liquids supplied at less than atmospheric pressure, in these negative pressure applications it is important that all connections be absolutely drip free and vacuum tight, and that a foot valve be installed at the bottom of the suction line (see Figure 5).
- When pumping a liquid near its boiling point, provide enough suction head to prevent the liquid from “flashing” into vapor when it enters the pump liquid end on the suction stroke.
 - If possible use metal or plastic tubing for the suction line because tubing has a smooth inner surface and can be formed into long, sweeping bends to minimize frictional flow losses.
 - A strainer should be used in the suction line to prevent foreign particles from entering the liquid end. This and any other measures which prevent debris from entering and fouling the ball-checks will give increased maintenance free service. Check strainer frequently to prevent blockage which could lead to cavitation.
 - Keep suction piping as short and straight as possible.
 - Piping size should be larger than the liquid end suction fitting to prevent pump starvation.
 - If long suction lines are unavoidable, install a stand pipe near the pump in the suction line.
 - Suction piping must be absolutely airtight to ensure accurate pumping. After installation, test suction piping for leaks with air and soap solution.

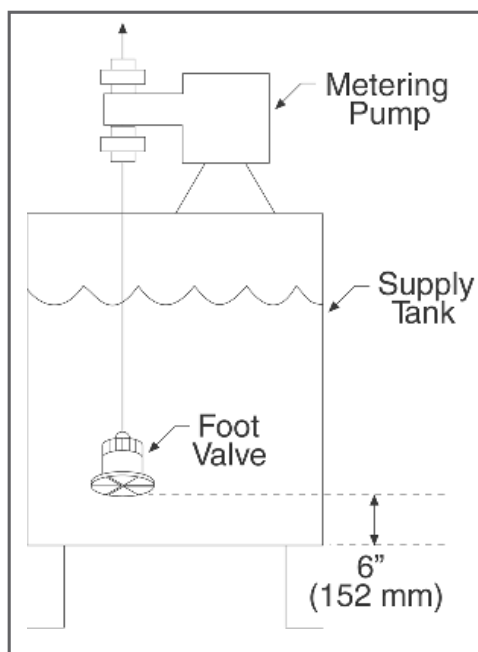

Figure 5. Suction Lift Installation

Discharge Piping Considerations

- Install pipe large enough to prevent excessive pressure losses on the discharge stroke of the pump. Maximum pressure at the discharge fitting on the liquid end must be kept at or below the rated pressure (Max. allowable working pressure shown on the pump nameplate).
- The pump will not deliver a controlled flow unless the discharge line pressure is 10 psi greater than the suction line pressure. There are a number of ways to create an artificial pressure, such as by installing a back pressure valve. (Please contact Milton Roy for recommendations to increase back pressure in slurry applications.)
- When pumping water-treatment chemicals directly into boiler drums, use one liquid end assembly for each boiler drum. Discharging into a manifold having the slightest pressure difference between its several discharge connections can diminish metering accuracy as the outlet with the lowest pressure will receive more liquid than the other outlets.

Back Pressure Valves

A Milton Roy Back Pressure Valve should be installed in the discharge line near the pump to ensure sufficient discharge head pressure for proper pump metering action. Normally, the valve should be located near the pump; however, back pressure valves for large pumps with long and extremely small discharge lines may have to be installed near the point of discharge into the process (to minimize siphoning tendencies).

Pulsation Dampeners

An accumulator, surge chamber, surge suppressor, or pulsation dampener should be used with the back pressure valve in the discharge line to absorb the flow peaks between the pump and the back pressure valve. Without the pulsation dampener the valve mechanism will snap open and closed with the surge from each pump stroke. The pulsation dampener will allow the back pressure valve to oscillate about a partly-closed position, thus minimizing wear on the valve. Discharge line pulsation dampeners offer the further advantage of limiting the flow and pressure variations characteristic of this kind of pump. Installing a properly sized pulsation dampener will improve pump performance and may reduce system costs dramatically by permitting the substitution of smaller piping. Please contact Milton Roy for further information on pulsation dampeners.

Safety Valves

Motor-driven positive displacement pumps can develop excessive discharge pressures long before thermal overload devices interrupt the motor electrical circuit. To prevent a blocked discharge line from causing damage to the pump, piping, or process equipment, install a Milton Roy Safety Valve in the pump discharge line. This valve is designed and sized to handle system flow rates and pressures safely while resisting corrosion by the process liquid.

Install the safety valve in the discharge line between the pump and the nearest shut-off valve. (This will prevent pump damage from accidental valve closure.) Pipe the safety valve outlet back to the suction tank or to drain, but in either case ensure that the pipe end is continuously visible so safety valve leakage may be detected. Milton Roy safety valves must be installed at top of supply tank in order to function properly (see *Figure 4*).

SECTION 2 - INSTALLATION

Check Valves

A check valve should be installed at the point where the discharge line enters a boiler or other high-pressure vessel. This will prevent back flow through the discharge piping and will isolate the pump discharge from system pressures (a safety consideration).

Shut-off Valves

Provide shut-OFF valves in both suction and discharge lines next to the pump. Locate discharge line shut-OFF valve downstream from the inlet connection of the safety valve. *Figure 4* shows recommended valve locations.

2.6 LEAK DETECTION

Without double diaphragm option:

MacRoy® G pumps are equipped with a leak detection port. For ease of installation, each pump has a plastic tubing connector installed in the leak detection port (See item 448 in *Figure 6, Sheet 2*). In the event of a failure of the oil seal (70 in *Figure 6, Sheet 1*) or PTFE diaphragm assembly (260 in *Figures 7 through 12*), pump drive oil or process fluid will escape from this leakage port. During pump installation, actions should be taken to insure that this leakage is safely collected by installing tubing between the leak detection port and an appropriate containment vessel.

With double diaphragm option:

The MacRoy® also is available with a double diaphragm option that includes tubing to a pressure gauge and switch as shown in *Figure 14*. In the event of a diaphragm leak the process fluid is trapped inside the system and the pressure switch (760, *Figure 14*) is tripped to set an alarm or shutdown.

This leak detection system is not filled with any fluid and will only be pressurized in the event of a seal failure. A drain (790, *Figure 14*) is provided for pressure relief prior to system disassembly.

2.7 ELECTRICAL CONNECTIONS

Ensure that the electrical supply matches the pump motor nameplate characteristics.

⚠ CAUTION OPERATION WITH THE WRONG MOTOR ROTATION WILL DAMAGE THE PUMP AND MOTOR AND VOID THE WARRANTY.

Before operating the pump, check the direction of rotation of the motor to be sure it matches the direction of the arrow stamped on the motor (rotation should be clockwise when viewed from the top of the motor). If motor rotation is incorrect, refer to the motor data plate or motor manufacturer's instructions for reversing.

⚠ CAUTION DO NOT FORGET TO CONNECT THE PUMP TO AN EARTH GROUND.

Electric protection of the motor (fuses, overload meters or relays) should correspond to the rated current indicated on the motor data plate.

3.1 INITIAL START-UP

▲ WARNING FAILURE TO CHECK TORQUE ON NONMETALLIC HEAD BOLTS PRIOR TO STARTUP AND AFTER ONE WEEK OF OPERATION MAY EXPOSE OPERATING PERSONNEL TO HAZARDOUS LIQUIDS.

Check the torque on all non-metallic head bolts prior to startup. Recheck torque on all non-metallic head bolts after pump has been operating for one week. Torque the head assembly screws in a crosswise pattern as follows:

1. Liquid End Size G5 and G6 non-metallic head bolts to 90 inch pounds.
2. Liquid End Size G7 non-metallic head bolts to 125 inch pounds.

Check that all mounting bolts are tight, piping is installed properly, and the discharge line is open. Check oil drain plug for tightness. Remove the oil fill cap and fill the pump casing until level is between the markings on the oil fill cap dipstick, (approximately 3 quarts (2.8 Liters)).

NOTE:

The oil furnished with the pump is grade AGMA No. 5 EP with a viscosity of 1000 SSU at 100°F (218.4 cSt at 40°C). For operation in ambient temperatures below 50°F (10°C), substitute AGMA No. 2 EP with a viscosity of 400 SSU at 100°F (86.4 cSt at 40°C). Manufacturers' equivalent oils are shown below.

ABOVE 50°F

Chevron	N.L. Gear Compound 220
Exxon	Spartan E.P. 220
Mobil	Mobilgear 630
Texaco	Meropa 220
Shell	Omaha 220

BELOW 50°F

Chevron	N.L. Gear Compound 68
Exxon	Spartan E.P. 68
Mobil	Mobilgear 626
Texaco	Meropa 68
Shell	Omaha 68

▲ CAUTION BEFORE SWITCHING ON POWER TO THE PUMP, TURN THE CAPACITY ADJUSTMENT KNOB TO ZERO. CHECK THAT ALL SHUT-OFF VALVES IN THE SUCTION AND DISCHARGE LINES ARE OPEN BEFORE INCREASING THE CAPACITY ADJUSTMENT FROM ZERO.

Manual Capacity Control

To adjust pump capacity, loosen the stroke locking knob (320, *Figure 6*, Sheet 2) located in the pump side cover. Pump capacity is adjusted by turning the micrometer type stroke adjustment knob (330) clockwise to decrease capacity or counterclockwise to increase capacity as required. The adjustment scale is marked in percent (%) of full stroke, with calibration lines on the knob at 1% intervals. After adjusting the knob to the desired capacity setting, hand tighten the stroke locking screw to maintain the capacity setting.

Filling Pumping System

It is especially important that pump suction and discharge lines be free of entrained air. To ensure this condition, operate the pump without any discharge pressure and fill the entire pumping system with liquid before starting pressure tests. A simple method to assure priming of the pump is to install a tee and a shut-off valve at the discharge connection of the pump.

If the pump is idle for long periods, temperature changes in the process liquid may produce air in the system. To discharge the air, install a valve in the discharge line which will allow the process liquid to be pumped to exhaust when starting the pump.

SECTION 3 - OPERATION

Capacity Calibration

After the first 12 hours of operation, the pump may be tested and calibrated to find the exact pump capacity under specific operating conditions.

Usually, calibrating the pump at only 100, 50 and 10 percent capacity settings is enough to indicate pump performance throughout the adjustment range.

The pump can be calibrated by measuring the decrease in liquid level pumped from a calibrated vessel. This method is recommended for hazardous liquids because it eliminates operator contact with the liquid. Milton Roy test-tube Calibration Columns are available for convenient and accurate calibration of any pump.

4.1 SPARE PARTS

To avoid excessive downtime in the event of a parts malfunction, the spare parts shown below should be stocked for each pump to prevent serious delays in repairs. Refer to *Figures 7-13* and the accompanying parts lists. For your convenience, these parts can be purchased either separately or packaged in the form of Routine Preventive Maintenance (RPM) Kits. RPM kit numbers are listed in Section 1.

RPM kit numbers RPM019 through RPM030 contain pre-assembled diaphragms, oil seal and check valve parts. Cap piece (240), set screw (250), diaphragm (260), and support nut (270) is pre-assembled in kits RPM019 through RPM030. A spanner wrench, which may not always be available in the field, is required to disassemble the diaphragm assembly.

RPM Kits RPM045 through RPM053, and RPM126 through RPM220 contain a diaphragm, oil seal, and check valve parts. MacRoy® G pumps built with the latest design do not need a spanner wrench to disassemble the diaphragm assembly. The diaphragm assembly can be disassembled with a 30mm socket (Section 4, paragraph 4.4.2). The diaphragm can then be replaced.

Either type of kit can be used for your pump. The user must decide which type is better for them. When ordering RPM Kits RPM045 through RPM053 for an old style pump, where a spanner wrench is required to disassemble the diaphragm assembly, order a new hex head support nut (270) with the RPM kit. Future maintenance on the MacRoy® pump will not require a spanner wrench.

G5, Metallic Liquid End

1. Diaphragm (260)
2. Oil Seal (70)
3. Check Valve Assemblies (425)

(See parts list)

All Other Liquid Ends

1. Diaphragm (260)
2. Oil Seal (70)
3. Seat, O-Ring, Ball Set (423)

(See parts list)

Parts orders must include the following:

1. Quantity required
2. Part number
3. Part description
4. Pump serial number (found on nameplate)
5. Pump model number (found on nameplate)
6. Pump product code (found on nameplate)

Always include the serial number, model number, and product code in all correspondence regarding the unit.

Drive Worms and Gears

Worms (Fig 6, Item 342) and gears (50) must be sold in sets to assure proper operation.

4.2 SHIPPING PUMPS FOR REPAIR

Pumps will not be accepted for repair without a Return Material Authorization Form, available from the Aftermarket Department or at the website (www.miltonroy.com). Process liquid must be flushed from the pump liquid end, and oil should be drained from the pump housing before the pump is shipped. Label the unit clearly to indicate the liquid being pumped.

NOTE:

Federal law prohibits handling of equipment that is not accompanied by an OSHA Safety Data Sheet (SDS). A completed SDS must be packed in the shipping crate with any pump returned to the factory. These safety precautions will aid the troubleshooting and repair procedure and preclude serious injury to repair personnel from hazardous residue in the pump liquid end.

All inquiries or parts orders should be addressed to your local Milton Roy representative. Representatives can be found on our website (www.miltonroy.com).

SECTION 4 - MAINTENANCE

4.3 PREVENTIVE MAINTENANCE

Milton Roy pumps are carefully designed, manufactured, assembled, and quality tested to give reliable service with minimal maintenance. However, a weekly maintenance check is recommended to visually confirm proper operation of the pump.

Drive

Initially, change gear drive oil after the first 250 hours of operation. Then change drive oil after every 4000 hours of operation or every six months, whichever comes first. Refer to “Initial Start-up” in Section 3, Operation, for information on recommended oil and oil capacity.

NOTE:

When adding oil, pour in a thin, slow stream to avoid overflow.

Diaphragm Assembly

The MacRoy® G diaphragm assembly should be replaced every 4000 hours of operation to avoid the possibility of failure. Refer to the instructions in the “Corrective Maintenance” section.

Oil Seal

The MacRoy® G oil seal should be replaced every 4000 hours of operation to avoid the possibility of failure. Oil seal replacement requires the removal of the diaphragm assembly, so it is recommended that the oil seal and diaphragm be replaced at the same time. Refer to the instructions in the “Corrective Maintenance” section.

Check Valves

Milton Roy recommends that check valve balls, seats, gaskets, and O-rings be replaced on an annual basis. If highly corrosive material (acids, slurries, etc.) is being pumped, some applications may require more frequent replacement.

To determine if check valves need maintenance, disassemble the check valves following the instructions in the “Corrective Maintenance” section.

Inspect the ball check and seat for chemical or physical damage. The ball should be perfectly round and free of pits, mars, or scratches. The seat should retain a sharp edge where the ball contacts for proper sealing. If the seat edge is worn or damaged, or has any pits, mars, or scratches, it should be replaced. If the ball and / or seat is excessively damaged, the replacement schedule should be shortened accordingly. If the ball and seat are both in good condition, the replacement schedule can be lengthened.

Complete instructions for replacing worn check valve parts are given in the “Corrective Maintenance” section.

4.4 CORRECTIVE MAINTENANCE

▲ CAUTION BEFORE CARRYING OUT ANY SERVICING OPERATION ON THE METERING UNIT OR PIPES, DISCONNECT ELECTRICAL POWER FROM THE PUMP, AND TAKE THE NECESSARY STEPS TO ENSURE THAT THE HARMFUL LIQUID THEY CONTAIN CANNOT ESCAPE OR COME INTO CONTACT WITH PERSONNEL. SUITABLE PROTECTIVE EQUIPMENT MUST BE PROVIDED. CHECK THAT ALL PRESSURE HAS BEEN BLED FROM THE PUMP DRIVE AND PUMP LIQUID END BEFORE PROCEEDING WITH DISMANTLING.

Cleaning Fouled Check Valves

Check valve assemblies are designed to be self cleaning and should seldom need servicing. Fouled check valves can usually be cleaned by pumping a solution of mild detergent and warm water (if compatible with liquid being pumped) for 15 minutes, followed by flushing with water.

4.4.1 Check Valve Replacement

General

Before beginning work on the valve assemblies, make sure the shut-off valves are closed and that pressure has been bled from the system. When replacing the valves, take care to systematically change their O-rings and / or gaskets. Take care to properly assemble the valve assemblies; the ball must be placed on the sharp edge of the seats.

Check valves are supplied in four different configurations: plastic, stainless steel, slurry, and polymer. Be sure to refer to the appropriate instructional set below.

▲ CAUTION BE SURE TO FOLLOW INSTRUCTIONS CAREFULLY AND REFER TO THE APPROPRIATE FIGURE WHEN REASSEMBLING CHECK VALVES. IF CHECK VALVE CARTRIDGES ARE INSTALLED INCORRECTLY, ONE OF THE FOLLOWING WILL OCCUR: (A) IMMEDIATE SEVERE DAMAGE TO PUMP MECHANISM, (B) NO PUMPING, (C) REVERSE PUMPING ACTION (FROM DISCHARGE LINE INTO SUCTION LINE).

4.4.1.1 Plastic Check Valves (PVC, PVDF, Poly, H₂SO₄, *Figure 13A or 13C*):

Disassembly

Check pump data plate for model number.

1. Unscrew the union nut (435). The union end (445) is held in place by the union nut and will separate easily from the other liquid end parts.
2. Unscrew the ball guide (424) from the liquid end.
3. Screw the union nut part way (one or two turns) onto the end of the ball guide that has the seat in it. Be sure the union nut is on loosely. This will allow a gap for the seat (420) to fall into as it is removed from the ball guide.
4. Set the ball guide / union nut onto a flat surface with the union nut down. Looking into the top of the ball guide, you will see four large holes surrounding one small hole. Insert a thin, blunt instrument such as a hex head screwdriver into the small center hole until it rests on the top of the ball (422).

▲ CAUTION IF YOU ARE DISASSEMBLING UNIT OR INSPECTION ONLY, BE SURE TO USE A BLUNT INSTRUMENT AND TAP GENTLY TO AVOID DAMAGING THE BALL. IF THE BALL AND / OR SEAT ARE DAMAGED DURING DISASSEMBLY, THEY WILL HAVE TO BE REPLACED. IF AVAILABLE, TO AVOID DAMAGE, IT IS ADVISABLE TO USE GENTLE AIR PRESSURE (APPLIED AT END OPPOSITE THE SEAT - 420) FOR BALL AND SEAT REMOVAL.

5. Tap screwdriver gently with a hammer until the ball and seat are released from the ball guide.
6. Carefully remove the two or three O-rings (depending on model number) from the ball guide and seat.
7. Carefully clean any parts to be reused. If any chemicals are used in the cleaning process, ensure that they are compatible with the process liquid.

SECTION 4 - MAINTENANCE

Reassembly

1. Fit new O-rings into position on the ball guide and seat.

NOTE:

To assure a tight, leak free seal, new O-rings should be used each time the check valves are disassembled.

2. Drop the ball into the curved inner chamber end of the ball guide.

CAUTION IF THE SEAT IS IMPROPERLY POSITIONED, THE BALL WILL NOT CREATE A TIGHT SEAL AND POOR PUMPING PERFORMANCE WILL RESULT.

3. Set the ball guide on a flat surface so that the side with the ball faces upwards. Position seat on the ball guide, trapping the ball inside. When the seat is pressed into the ball guide, the bevelled edge of the seat must be facing outward. The bevel should not face the inside of the check valve (refer to *Figure 13A or 13C*). Use a flat surface such as a board to press the seat into the ball guide with firm, even pressure.

CAUTION THE ORDER OF ASSEMBLY AND ORIENTATION OF THE SUCTION AND DISCHARGE CHECK VALVES IS DIFFERENT. REFER TO FIGURES 7, 9, 11, 13A, AND 13C FOR PROPER ASSEMBLY ORDER AND ORIENTATION. IF CHECK VALVE CARTRIDGES ARE INSTALLED INCORRECTLY, ONE OF THE FOLLOWING WILL OCCUR: (A) IMMEDIATE SEVERE DAMAGE TO PUMP MECHANISM, (B) NO PUMPING, (C) REVERSE PUMPING ACTION (FROM DISCHARGE LINE INTO SUCTION LINE).

4. Position the union end (445) onto the correct end of the ball guide. Refer to *Figure 13A or 13C*, as the correct end is determined by whether the valve is intended for the suction or discharge port of the liquid end. Slip the union nut (435) over the union end and screw tightly (hand tight only) onto the ball guide.
5. Screw the valve assembly into the liquid end body (**hand tight only**), **Do not over tighten**.

4.4.1.2 Models G6 & G7 Liquid Ends - Stainless Steel Check Valves (PVC, PVDF, Poly, H₂SO₄, *Figure 13D*):

Disassembly

1. Unscrew the three screws (441 & 442) and remove them and their three washers (439).
2. Remove the valve clamp (437).
3. The connection (435), seat (420), ball (422) and ball guide (424) should all now slip apart easily.
4. Remove and discard the three gaskets (419).
5. Carefully clean any parts to be reused. If any chemicals are used in the cleaning process, ensure that they are compatible with the process liquid.

Reassembly

1. Drop the ball into the curved inner chamber end of the ball guide.

CAUTION DO NOT REUSE OLD GASKETS (419). EVEN IF BALL AND SEAT ARE NOT WORN AND DO NOT NEED REPLACING, NEW GASKETS MUST BE USED ANY TIME THE CHECK VALVES ARE DISASSEMBLED.

2. Place a new gasket on the rim of the ball guide (424), and sit the seat on top of the ball guide, trapping the ball and gasket between the seat and ball guide.

CAUTION THE ORDER OF ASSEMBLY AND ORIENTATION OF THE SUCTION AND DISCHARGE CHECK VALVES IS DIFFERENT. REFER TO FIGURES 10, 12, AND 13D FOR PROPER ASSEMBLY ORDER AND ORIENTATION. IF CHECK VALVE CARTRIDGES ARE INSTALLED INCORRECTLY, ONE OF THE FOLLOWING WILL OCCUR: (A) IMMEDIATE SEVERE DAMAGE TO PUMP MECHANISM, (B) NO PUMPING, (C) REVERSE PUMPING ACTION (FROM DISCHARGE LINE INTO SUCTION LINE).

3. Position the connection (435) onto the correct end of the ball guide with a gasket trapped between the two metal surfaces. Refer to *Figure 13D*, as the correct end is determined by whether the valve is intended for the suction or discharge port of the liquid end.
4. Position the check valve assembly onto the liquid end, trapping a gasket between the two metal surfaces (Seat and pump head).
5. Slide the valve clamp (437) over the connection (435) and screw into the liquid end using the three screws (441,442) and their split washers (439). Since one screw (441) is shorter than the others, be sure that it is screwed into the appropriate hole.

4.4.1.3 Model G5 Liquid End - Stainless Steel Check Valve (PVC, PVDF, POLY, H₂SO₄, *Figure 13B*):

Disassembly

G5 & G6 stainless steel check valves differ from the plastic versions in that the ball seat is integral to the ball guide. The seats cannot easily be inspected for damage or wear. If you suspect that the check valve may be damaged or worn, replace the entire check valve assembly as per the instructions below.

1. Unscrew the coupling (445).
2. Unscrew the ball guide (424) from the liquid end.
3. Remove and discard the O-rings (419).
4. Carefully clean any parts to be reused. If any chemicals are used in the cleaning process, ensure that they are compatible with the process liquid.

Reassembly

▲ CAUTION THE ORDER OF ASSEMBLY AND ORIENTATION OF THE SUCTION AND DISCHARGE CHECK VALVES IS DIFFERENT. REFER TO *FIGURES 8 AND 13B* FOR PROPER ASSEMBLY ORDER AND ORIENTATION. IF CHECK VALVE CARTRIDGES ARE INSTALLED INCORRECTLY, ONE OF THE FOLLOWING WILL OCCUR: (A) IMMEDIATE SEVERE DAMAGE TO PUMP MECHANISM, (B) NO PUMPING, (C) REVERSE PUMPING ACTION (FROM DISCHARGE LINE INTO SUCTION LINE).

1. Screw the correct end of the check valve assembly into the liquid end (Refer to *Figure 13B*), trapping a new O-ring between the liquid end and the check valve assembly.

NOTE:

To assure a tight, leak free seal, new O-rings should be used each time the check valves are disassembled.

2. Screw the coupling (445) onto the check valve assembly, trapping a new O-ring (419, 423) between the coupling and the check valve assembly.

4.4.1.4 Model G5 Liquid End - Slurry Check Valves:

Replacement

▲ CAUTION THE ORDER OF ASSEMBLY AND ORIENTATION OF THE SUCTION AND DISCHARGE CHECK VALVES IS DIFFERENT. REFER TO *FIGURES 7 AND 13E* FOR PROPER ASSEMBLY ORDER AND ORIENTATION. IF CHECK VALVE CARTRIDGES ARE INSTALLED INCORRECTLY, ONE OF THE FOLLOWING WILL OCCUR: (A) IMMEDIATE SEVERE DAMAGE TO PUMP MECHANISM, (B) NO PUMPING, (C) REVERSE PUMPING ACTION (FROM DISCHARGE LINE INTO SUCTION LINE).

1. Unscrew the coupling (445).
2. Unscrew the valve body (424) from the pump head (280).
3. Remove and discard the valve assembly: assembly includes two O-rings (419), slurry seal ring (420), ball (422), check valve body (424) and dowel pin.
4. Clean the new valve assembly and threaded port in the head (280).

SECTION 4 - MAINTENANCE

NOTE:

To assure a tight, leak free seal, new O-rings should be used each time the check valves are disassembled.

5. Screw the correct end of the check valve assembly into the liquid end (Refer to *Figure 13E*), trapping a new O-ring (419) between the liquid end and the check valve assembly.
6. Screw the coupling (445) onto the check valve assembly, trapping a new O-ring (419) between the coupling and the check valve assembly.

4.4.1.5 Models G6 & G7 Liquid End - Slurry Check Valves (*Figure 13G*):

Replacement

▲ CAUTION THE ORDER OF ASSEMBLY AND ORIENTATION OF THE SUCTION AND DISCHARGE CHECK VALVES IS DIFFERENT. REFER TO *FIGURE 13G* FOR PROPER ASSEMBLY ORDER AND ORIENTATION. IF CHECK VALVE CARTRIDGES ARE INSTALLED INCORRECTLY, ONE OF THE FOLLOWING WILL OCCUR: (A) IMMEDIATE SEVERE DAMAGE TO PUMP MECHANISM, (B) NO PUMPING, (C) REVERSE PUMPING ACTION (FROM DISCHARGE LINE INTO SUCTION LINE).

1. Unscrew the valve body (424) from the pump head (280).
2. Remove the valve assembly: assembly includes ball (421), seat (420), valve body (424), and three O-rings (419).
3. Remove and discard the O-rings (419), seat (420) and ball (421).
4. Clean the valve body (424) and threaded port in the head (280).
5. Place a new O-ring (419) around seat (420). Place new seat (420) and new ball (422) inside valve body (424).
6. Add O-ring (419) and install new check valve assembly in orientation shown.

NOTE:

To assure a tight, leak free seal, new O-rings should be used each time the check valves are disassembled.

7. Screw the correct end of the check valve assembly into the liquid end (Refer to *Figure 13G*), trapping a new O-ring (419) between the liquid end and the check valve assembly.
8. Screw the coupling (445) onto the check valve assembly, trapping a new O-ring (419) between the coupling and the check valve assembly.

4.4.1.6 Models G5, G6 & G7 Liquid End - Polymer Check Valves (*Figure 13F*): Replacement

Suction

Follow the instruction for replacement of ball, seat, & seal: liquid end G6 and G7 - plastic check valves paragraph 4.4.1.1. The procedures are the same.

Discharge

1. Unscrew the valve body (425) from the pump head (280).
2. Remove the valve assembly: assembly includes two O-rings (419), seat (420), ball (422), poppet (426), spring (423) and check valve body (425).
3. Replace O-rings (419), seat (420), ball (422), poppet (426), and spring (423).
4. Clean the valve body (425) and threaded port in the head (280).
5. Install new check valve assembly in orientation shown.

On discharge side, drop cartridge assembly into threaded port in head. Screw valve body into discharge side of diaphragm head until valve is hand tight. **Do not overtighten.**

4.4.2 Diaphragm Replacement

▲ CAUTION BEFORE BEGINNING DIAPHRAGM REPLACEMENT, MAKE SURE THAT ALL SHUT-OFF VALVES ARE CLOSED AND ALL PRESSURE IS BLED FROM THE LIQUID END. MAKE SURE POWER TO PUMP IS TURNED OFF AND CANNOT BE ACTIVATED.

It is recommended that the oil seal and diaphragm be replaced at the same time. The instructions given under “Replacing the Oil Seal” are complete instructions for replacing both the oil seal and diaphragm. If you plan to replace both, refer to the “Replacing the Oil Seal” instructions, and disregard the instructions below. These instructions are intended for use only if the diaphragm is being replaced independent of the oil seal.

4.4.2.1 Diaphragm Removal (All types; Refer to *Figures 6-12*)

1. Set the stroke adjusting knob to 100%.
2. Disconnect the suction and discharge piping.
3. Unscrew the six diaphragm head bolts (290).
4. Remove the pump head (280) from the pump body.
5. Turn the motor fan by hand (remove the motor shroud if necessary) until the end of the diaphragm (240) is fully forward, and unscrew the diaphragm assembly from the connecting rod (60).

4.4.2.2 Disassembly (Only Those Units With a “Hex Head “ Diaphragm Cap Design)

1. Secure the hex cap (240) in a vise, and loosen the support nut (270) using a 30mm hex socket.
2. After complete disassembly inspect the support nut (270). It should be free of corrosion and clean. The angled surface must be smooth to protect the diaphragm from damage. If the support nut does not meet these requirements, replace it.

4.4.2.3 Reassembly

1. Mount the hex cap (240) in a vise (Do not overtighten), and with surfaces cleaned place a new diaphragm (260) onto the cap as shown *Figures 7 through 12* (convolution pointing toward the support nut).
2. Hand tight the set screw (250) in the cap (240) with the hex socket end visible.
3. Screw the support nut (270) onto the set screw until hand tight
4. **Do not overtighten** the support nut. Use a 30mm hex socket and torque wrench to tighten the support nut. The torque depends on pump model number.
 - a. For model numbers G5 & G6: Torque is 20 foot pounds.
 - b. For model number G7: Torque is 25 foot pounds.

4.4.2.4 Reinstallation of Assembly (Refer to *Figures 6 Through 12*)

1. With the stroke adjusting knob at 100% and the diaphragm fully forward as in steps 1 and 5 of paragraph 4.4.2.1, screw the diaphragm assembly into the connecting rod until it reaches its natural mechanical stop.
2. Turn the motor fan by hand until the diaphragm rests properly on the diaphragm support (230). Reinstall the motor shroud if previously removed.
3. Fit the diaphragm head back into place on the pump body.
4. Torque the six diaphragm head bolts to the following inch pounds in a crisscross pattern:
 - a. Liquid End Size G5 and G6 metallic and non-metallic head bolts to 90 inch pounds.
 - b. Liquid End Size G7 non-metallic head bolts to 125 inch pounds.
 - c. Liquid End Size G7 metallic head bolts to 250 inch pounds.

4.4.3 Replacing Oil Seal

CAUTION BEFORE BEGINNING OIL SEAL REPLACEMENT, MAKE SURE THAT ALL SHUT-OFF VALVES ARE CLOSED AND ALL PRESSURE IS BLED FROM THE LIQUID END. MAKE SURE POWER TO PUMP IS TURNED OFF AND CANNOT BE ACTIVATED.

When replacing the oil seal, the diaphragm assembly must be removed first. For ease of service, it is recommended that the oil seal be replaced in conjunction with the diaphragm assembly. Therefore, the instructions below include the “Diaphragm Replacement” instructions, and can be used for both oil seal replacement and diaphragm replacement.

Disassembly (Refer to Figures 6 through 12).

1. Drain oil from the pump by unscrewing drain plug and O-ring, located underneath capacity adjustment knob (330).
2. Set the capacity adjusting knob (330) to 100%.
3. Disconnect the suction and discharge piping.
4. Unscrew the six diaphragm head bolts.
5. Remove the diaphragm head assembly from the pump body.
6. Turn the motor fan by hand (remove the shroud if necessary) until the end of the diaphragm assembly (240) is fully forward, and unscrew the diaphragm from the connecting rod (60), using a 30mm hex socket on diaphragm cap (240).
7. Remove the diaphragm support ring (230).
8. Remove the retaining ring (220) from the connecting rod.
9. Slide the small oil seal clamp (210) off the connecting rod.
10. Remove the large oil seal clamp (80) by unscrewing the four slotted screws (90).
11. Pull the oil seal (70) off of the connecting rod.

Reassembly (Refer to Figures 6 through 12).

1. Install a new oil seal (70) onto the connecting rod.
2. Slide small oil seal clamp (210) onto the end of the connecting rod and secure in place with the retaining ring (220). A drive socket large enough to fit over the end of the connecting rod should be used to push the retaining ring until it snaps into place in the retaining ring groove in the connecting rod.
3. Secure the large oil seal clamp (80) over the oil seal with the four slotted screws (90).
4. Place the diaphragm support ring (230) into position making sure bevelled side (for diaphragm support) is facing up (refer to Figures 6 through 12). For G7 liquid ends, the support ring (230) has stepped diameters. Make sure that the larger diameter is installed into the metal adapter ring (225 Figures 11 and 12).
5. With the stroke adjusting knob at 100% and the diaphragm fully forward as in steps 2 and 6 of disassembly instructions, screw the diaphragm assembly into the connecting rod until it reaches its natural mechanical stop.
6. Turn the motor fan by hand until the diaphragm rests properly on the diaphragm support ring (230). Reinstall the motor shroud if previously removed. With the stroke adjusting knob at 100% and the diaphragm fully forward as in steps 2 and 6 of disassembly instructions, screw the diaphragm assembly into the connecting rod until it reaches its natural mechanical stop.
7. Fit the diaphragm head back into place on the pump body.

8. Torque the six diaphragm head bolts to the following inch pounds in a crisscross pattern:
 - a. Liquid End Size G5 and G6 metallic and non-metallic head bolts to 90 inch pounds.
 - b. Liquid End Size G7 non-metallic head bolts to 125 inch pounds.
 - c. Liquid End Size G7 metallic head bolts to 250 inch pounds.
4. Add oil to pump, following directions given in “Initial Start-up” in Section 3.

SECTION 5 - TROUBLESHOOTING GUIDE

SYMPTOMS	REMEDIES
Pump will not operate	<ul style="list-style-type: none"> • Low process liquid level in the tank. Add liquid. • Worn or dirty check valves. Clean or replace. • Blocked discharge line. Clear line. • Frozen liquid. Thaw liquid throughout pumping system. • Blown fuse. Replace fuse. • Open thermal overload device in motor starter. Reset device. • Broken wire. Locate and repair. • Low voltage. Investigate and correct (wiring may be too light). • Pump not primed. Allow suction line and pump head to fill with liquid before pumping against pressure. Refer to “Filling Pumping System” in Section 3. • Capacity adjustment set at zero. Readjust capacity.
Insufficient delivery	<ul style="list-style-type: none"> • Incorrect capacity adjustment. Readjust capacity setting. • Incorrect pump seed. Match live voltage and frequency to pump motor data plate. • Starved suction. Increase piping size or suction head. • Leaky suction piping. Repair piping. • High suction lift. Rearrange equipment to decrease lift. • Liquid near boiling. Cool liquid or increase suction head. • Leaky safety valve in discharge line. Repair or replace safety valve. • High liquid viscosity. Reduce viscosity (e.g. heat or dilute liquid). • Worn or dirty check valve seats. Clean or replace.
Erratic delivery	<ul style="list-style-type: none"> • Leaky suction piping. Repair piping. • Leaky safety valve. Repair or replace safety valve. • Insufficient suction head. Raise suction tank level or pressurize tank. • Liquid near boiling. Cool liquid or increase suction head. • Worn or dirty check valves. Clean or replace. • Clogged or dirty line strainer. Clean strainer.
Motor and pump body hot	<ul style="list-style-type: none"> • Normal operating temperature of both motor and pump body is frequently uncomfortable to the touch. However, neither should exceed 200°F (93°C). • Power supply does not match electrical requirement of motor. Insure proper matching of power supply and motor. • Pump is being operated at greater than rated performance. Reduce pressure or stroke speed. If this is not practical, contact service facility. • Pump improperly lubricated. Drain oil and refill with proper amount of recommended lubricant.
Pump still pumps even at zero capacity setting	<ul style="list-style-type: none"> • Improperly adjust micrometer knob. Readjust capacity setting. • Insufficient discharge pressure. Correct condition. • Siphoning of liquid in discharge line. Install a back pressure valve.
Gear Noise	<ul style="list-style-type: none"> • Excessive backlash. Consult service facility. • Worn bearings. Consult service facility. • Wrong or insufficient lubricant. Replace or replenish lubricant.
Loud knock with each stroke	<ul style="list-style-type: none"> • Excessive gear set wear. Consult service facility. • Worn bearings. Consult service facility.
Noisy operation in liquid end	<ul style="list-style-type: none"> • Noise in check valves. Ball checks move up and down with some force. A distinct “clicking” noise is normal, especially in metal piping systems.

6.1 GENERAL

This section gives information regarding replaceable components.

6.2 ILLUSTRATED PARTS LIST

1. Figure and Item Number Column

- a. The item numbers shown in the detailed parts list correspond to the item numbers appearing on the exploded view illustration. To find an unknown part number, locate the part on the illustration and note the item number. Look for the item number on the detailed parts list. The part number is on the same line. A dash (-) precedes non-illustrated item numbers.

2. Description Column

- a. The name of the item is in the description column.

3. Part Number Column

- a. The supplier's part number is listed in the part number column.

4. Quantity Column

- a. The numbers appearing in the quantity column are the total quantity of the listed part required in its immediate assembly.

5. Reference Code Column

- a. This column is used to denote assembly and detail part variations among similar components (models) covered by this publication. When the symbol "A1", "B1", "C1", etc. is entered in this column, the part is used only in the model (liquid end and material codes, see *Figure 1* and pump data plate) at which the symbol appears. If the column is blank, the part is used in all models.

Refer to table numbers (6.3 to 6.12) for the above Parts List information.

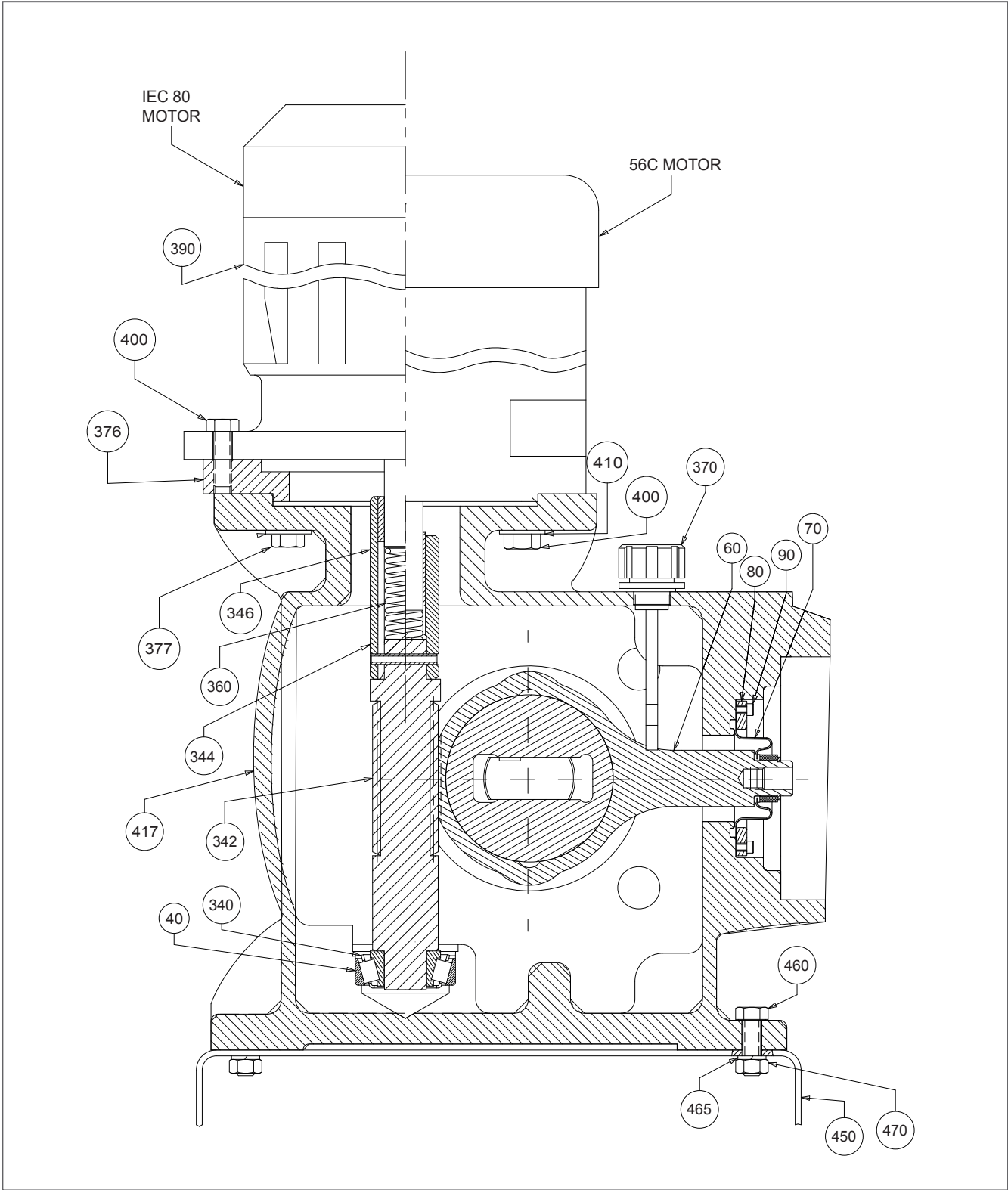

Figure 6A. MacRoy® G Drive Parts - Side View (DWG 102-1999-0001)

6.3 DRIVE, SIDE VIEW

FIGURE NUMBER	ITEM NUMBER	DESCRIPTION	PART NUMBER	QTY	REFERENCE CODE
6	40	Bearing Cup (Timken)	4090116050	1	
	60	Connecting Rod	S60654	1	
	70	Oil Seal, Buna N	60048	1	
	80	Oil Seal Clamp, Aluminum	60034	1	
	90	Slotted Pan Head Screw, M3x10, 304SS	60294	4	
	340	Bearing Cone (Timken) (See Note 1)	4090116040	1	
	342	Worm, 8:1 (See Note 1)	S60198	1	
	342	Worm, 10:1 (See Note 1)	S60195	1	
	342	Worm, 14:1 (See Note 1)	S60828	1	
	342	Worm, 20:1 (See Note 1)	S60196	1	
	342	Worm, 40:1 (See Note 1)	S60197	1	
	-	Worm Assembly (43 SPM, 56C, 40:1), Gear S60011 (See Note 1)	60397	1	
	-	Worm Assembly (36 SPM, IEC 80 Frame, 40:1), Gear S60011 (See Note1)	60224	1	
	-	Worm Assembly (86 SPM, 56C, 20:1), Gear S60009 (See Note 1)	60396	1	
	-	Worm Assembly (72 SPM, IEC 80 Frame, 20:1), Gear S60009 (See Note1)	60223	1	
	-	Worm Assembly (173 SPM, 56C, 10:1), Gear S60007 (See Note 1)	60395	1	
	-	Worm Assembly (144 SPM, IEC 80 Frame, 10:1), Gear S60007 (See Note1)	60222	1	
	-	Worm Assembly (180 SPM, IEC 80 Frame, 8:1), Gear S60050 (See Note 1)	60221	1	
	344	Spring Pin, 0.187 x 1-1/8 STL (See Note 1)	4010005101	1	
	346	Worm Shaft Coupling, 56C (See Note1)	60261	1	
	346	Worm Shaft Coupling, IEC 71 (See Note 1)	60260	1	
	346	Worm Shaft Coupling, IEC 80 (See Note 1)	60194	1	
	360	Spring (56C) (See Note 2)	60264	1	
	360	Spring (IEC 80) (See Note 2)	60225	1	
	370	Vent with Dip Stick	70067	1	
	376	IEC 80 Motor Adapter Ring	60199	1	
	377	Hex Head Screw, M10 x 25MM Steel (IEC 80 motor)	4350001732	4	

- Parts Not Illustrated

DRIVE, SIDE VIEW

FIGURE NUMBER	ITEM NUMBER	DESCRIPTION	PART NUMBER	QTY	REFERENCE CODE
6	390	Motor (1 hp, 1 ph, 1800 rpm, 115/230, 60 hz, 56C)	4112008010	1	
	390	Motor (1 hp, 3 ph, 1500 rpm, 220/380, 50 hz, 56C)	4112008315	1	
	390	Motor (1hp, 3 ph, 1800 rpm, 230/460, 60 hz, 56C)	4112008310	1	
	390	Motor (1 hp, 1750 rpm, 90 VDC, PM - TEFC-56C)	4112008610	1	
	390	Motor (1 hp, W/VAR SPD AC Drive)	60297	1	
	400	Hex Head Screw (3/8-16 x 1) (56C motor)	4050018119	4	
	400	Hex Head Screw (M10 x 25 mm) (IEC 80 motor)	4350001732	4	
	410	Flat Washer (3/8) (56C motor)	4040009012	4	
	410	Flat Washer (M10) (IEC 80 motor)	4340005152	4	
	417	Caution, Motor Decal G	60148	1	
	450	Base	61266	1	
	460	Hex Head Screw (M8 x 35 mm)	4350035542	4	
	465	Spring Lock Washer (8 mm)	4340009002	4	
	470	Hex Nut (M8)	4350000042	4	

Note 1:

Worm-Gear-Shaft Assembly includes gear (50) worm (342), spring pin (344), spring (360), worm shaft coupling (346), and bearing cone (340). Gear (50) and worm (342) sold only as assembly (343)

Note 2:

Part number for 56C motor spring (60264) applies to two-piece worm assembly: worm and motor coupling piece joined together by a spring pin (344). If worm is previous one-piece design (no spring pin), the correct 56C motor spring part number is 60059.

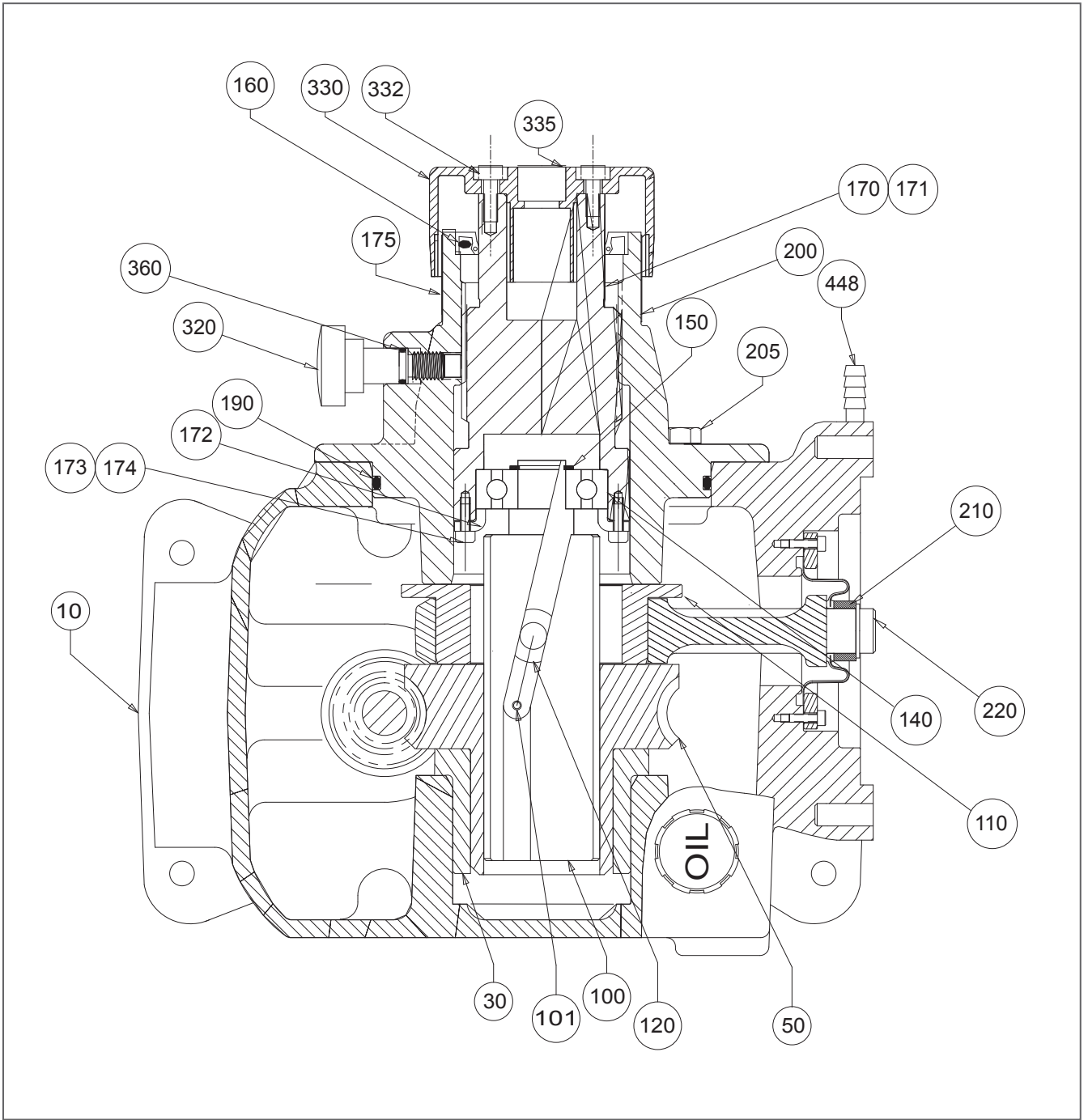

Figure 6B. MacRoy® G Basic Parts - Top View (DWG 102-1999-0001)

6.4 DRIVE, TOP VIEW

FIGURE NUMBER	ITEM NUMBER	DESCRIPTION	PART NUMBER	QTY	REFERENCE CODE
6	10	Drive Housing Assembly (Includes Items 30, 40, and 448)	60001	1	
	10	Housing, Stroke Counting (Includes Items 30, 40, and 448)	60877	1	
	30	Thrust Bearing, Bronze	60014	1	
	50	Gear (36/43 SPM), 50 Hz/60 Hz (See Note 1)	S60011	1	
	50	Gear (72/86 SPM), 50 Hz/60 Hz (See Note 1)	S60009	1	
	50	Gear (103/123 SPM), 50 Hz/60 Hz (See Note 1)	S60829	1	
	50	Gear (144/173 SPM), 50 Hz/60 Hz (See Note 1)	S60007	1	
	50	Gear (180 SPM), 50 Hz (See Note 1)	S60050	1	
	100	Sliding Crank	60002	1	
	101	Spring Pin, 0.125 x 1/2	4010003031	1	
	110	Eccentric, Steel	60003	1	
	110	Eccentric, Stroke Counting	60875	1	
	120	Shoe	60052	1	
	140	Single Row Bearing	4099994000	1	
	150	Truarc Retaining Ring	4040107231	1	
	160	Parker O-ring, Buna N	4080095171	1	
	170	Stroke Adjustment Screw Assembly	60950	1	
	171	Stroke Screw, Part of Item 170	H60768	1	
	172	Bearing Retainer, Part of Item 170	H60757	1	
	174	Socket Head Screw M4 x 8MM, Part of item 170	41663	4	
	175	Stroke Scale	2530046062	1	
	185	Dowel Pin 1/8 x 1-3/8, Part of Item 170	4010021143	1	
	190	Parker O-ring (2-246), Buna N	4080095371	1	
	200	Cover	H60767	1	
	205	Hex Head Screw (M8 x 16 mm)	4350001622	4	
	210	Oil Seal Clamp, Aluminum	60043	1	
	220	Truarc Retaining Ring	4040133060	1	
	-	M12 Lockwasher, 18-8SS	4340009095	6	
	-	M12 Hex Nut, 304SS	4350000085	6	
	310	Ball 5/16, Nylon	60152	1	

- Parts Not Illustrated

DRIVE, TOP VIEW

FIGURE NUMBER	ITEM NUMBER	DESCRIPTION	PART NUMBER	QTY	REFERENCE CODE
6	320	Stroke Locking Knob	60398	1	
	322	O-Ring, 2-012 Bunan N	4080109091	1	
	330	Stroke Adjustment Knob	70066	1	
	331	Flat Washer 1/4", 18.8SS	4040005012	1	
	332	Pan Head Screw #8 x 1-1/2", 18.8SS	40722	1	
	335	Logo Decal (Stroke Knob)	70022	1	
	448	Tubing Connector (1/4" OD x 1/4" ID)	4020479028	1	
	-	Gear Oil (AGMA 5 EP, ZURN EP95) - 1 Quart Can	4070152010	3	

Note 1:

Worm-Gear-Shaft Assembly includes gear (50) worm (342), spring pin (344), spring (360), worm shaft coupling (346), and bearing cone (340). Gear (50) and worm (342) sold only as assembly (343)

Note 2:

Part number for 56C motor spring (60264) applies to two-piece worm assembly: worm and motor coupling piece joined together by a spring pin (344). If worm is previous one-piece design (no spring pin), the correct 56C motor spring part number is 60059.

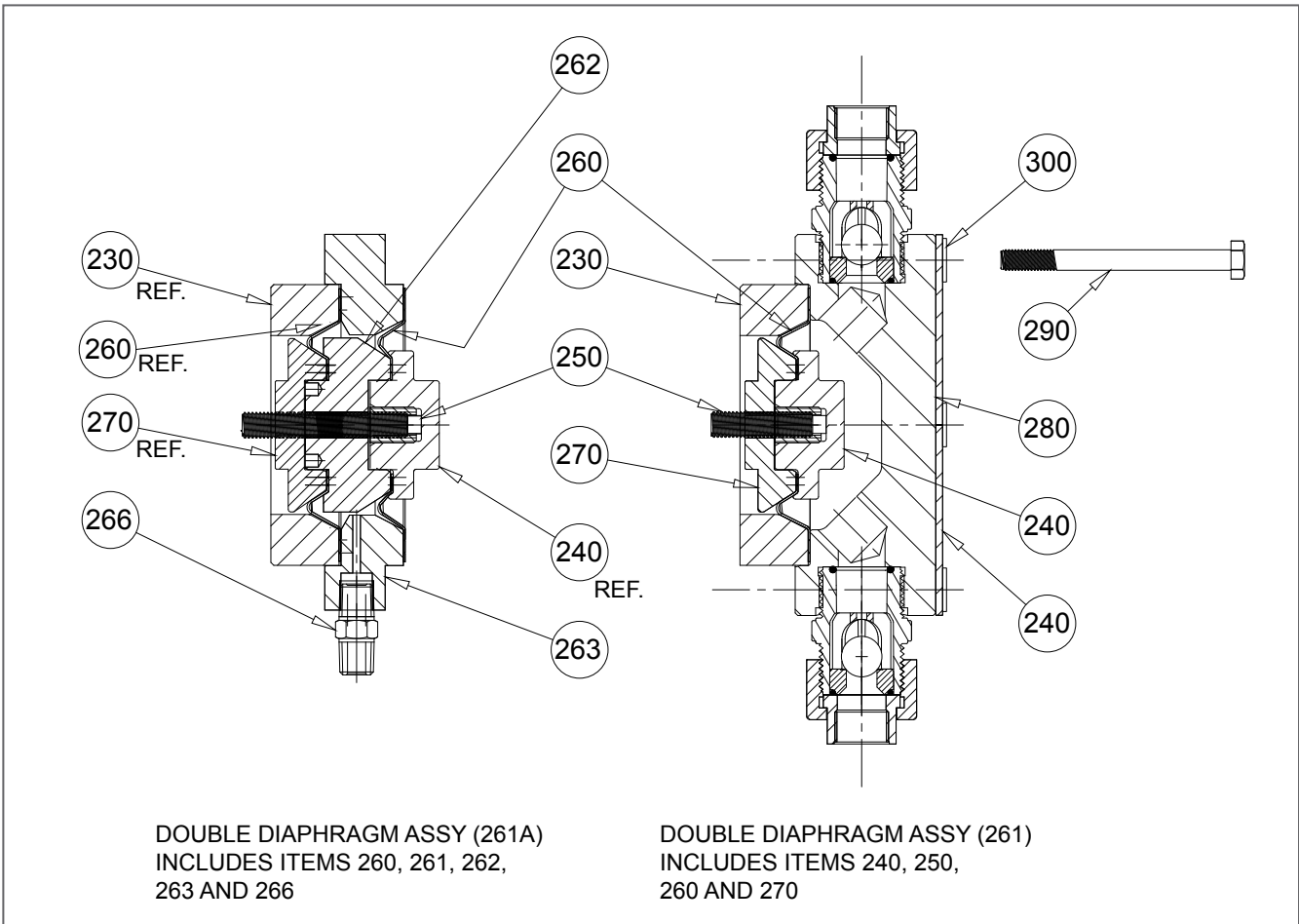

Figure 7. G5 Plastic Liquid End (DWG 102-1999-007)

6.5 G5 PLASTIC LIQUID END

Model:

Liquid End:	Material:	Reference Code:
G5	8	A (PVC)
G5	4	B (BLACK POLY)
G5	2	C (PVDF)
G5	A	D (ACRYLIC) (Consult Factory)
G5	P	E (POLYMER)
G5	L	F (SLURRY)
G5	N	G (H ₂ SO ₄)

FIGURE NUMBER	ITEM NUMBER	DESCRIPTION	PART NUMBER	QTY	REFERENCE CODE
7	230	Diaphragm Support Ring	60035	1	
	240	Diaphragm Cap, Part of Item 261	60628	1	A, E, F, G
	240	Diaphragm Cap, Part of Item 261	60629	1	B
	240	Diaphragm Cap, Part of Item 261	60630		C
	250	Set Screw, Dog Pt., M10 x 45 mm, Single Diaphragm, Part of Item 261	4350071284	-	A, B, C, E
	250	Set Screw, Dog Pt., M10 x 70 mm, Double Diaphragm, Part of Item 261A	4350071334	-	A, B, C
	260	Diaphragm, Part of Item 261	60618	1	
		Diaphragm, Part of Item 261A	60618	2	
	261	Diaphragm Assembly, (Replaceable Design, Consists of Items 240, 250, 260 and 270), See Note 1	60150	1	A, E, F, G
	261	Diaphragm Assembly, (Replaceable Design, Consists of Items 240, 250, 260 and 270), See Note 1	3050976110	1	B
	261	Diaphragm Assembly, (Replaceable Design, Consists of Items 240, 250, 260 and 270), See Note 1	3050976130	1	C
	261A	Double Diaphragm Assembly, (Replaceable Design, Consists of Items 260(2X), 261, 262, 263 and 266), See Note 2	60274	1	A, E, F, G
	261A	Double Diaphragm Assembly, (Replaceable Design, Consists of Items 260(2X), 261, 262, 263 and 266), See Note 2	60275	1	B

G5 PLASTIC LIQUID END

FIGURE NUMBER	ITEM NUMBER	DESCRIPTION	PART NUMBER	QTY	REFERENCE CODE
7	261A	Double Diaphragm Assembly, (Replaceable Design, Consists of Items 260(2X), 261, 262, 263 and 266), See Note 2	60276	1	C
	262	Double Diaphragm Spacer, PVC, Part of Item 261A	980367071	1	A, B, C
	263	Double Diaphragm Intermediate Ring (Included in double diaphragm assembly Item 261A)	980366071	1	A, B, C
	266	Hex Nipple 1/4 NPT connection, 316SS (Included in double diaphragm assembly, Item 261A)	60208	1	
	270	Diaphragm Support Nut, Part of Item 261	60632	1	
	280	Diaphragm Head, PVC	60033	1	A, E, F, G
	280	Diaphragm Head, White PP Diaphragm	60032	1	B
	280	Head, Black PP	60882	1	B
	280	Diaphragm Head, PVDF	60031	1	C
	290	Hex Head Screw, M8 x 90, Single Diaphragm	4350035655	6	A, B, C
	290	Hex Head Screw, M8 x 110, Double Diaphragm	4350001655	6	A, B, C
	300	Flat Washer (M8)	4340005085	6	
	300	Back-up Plate G5/G6	60754	1	B

Note 1:

Diaphragm Assembly (261) can be purchased assembled or items 240, 250, 260, and 270 can be purchased separately.

Note 2:

Double Diaphragm Assembly (261A) can be purchased assembled or items 260, 261, 262, 263 and 266 can be purchased separately.

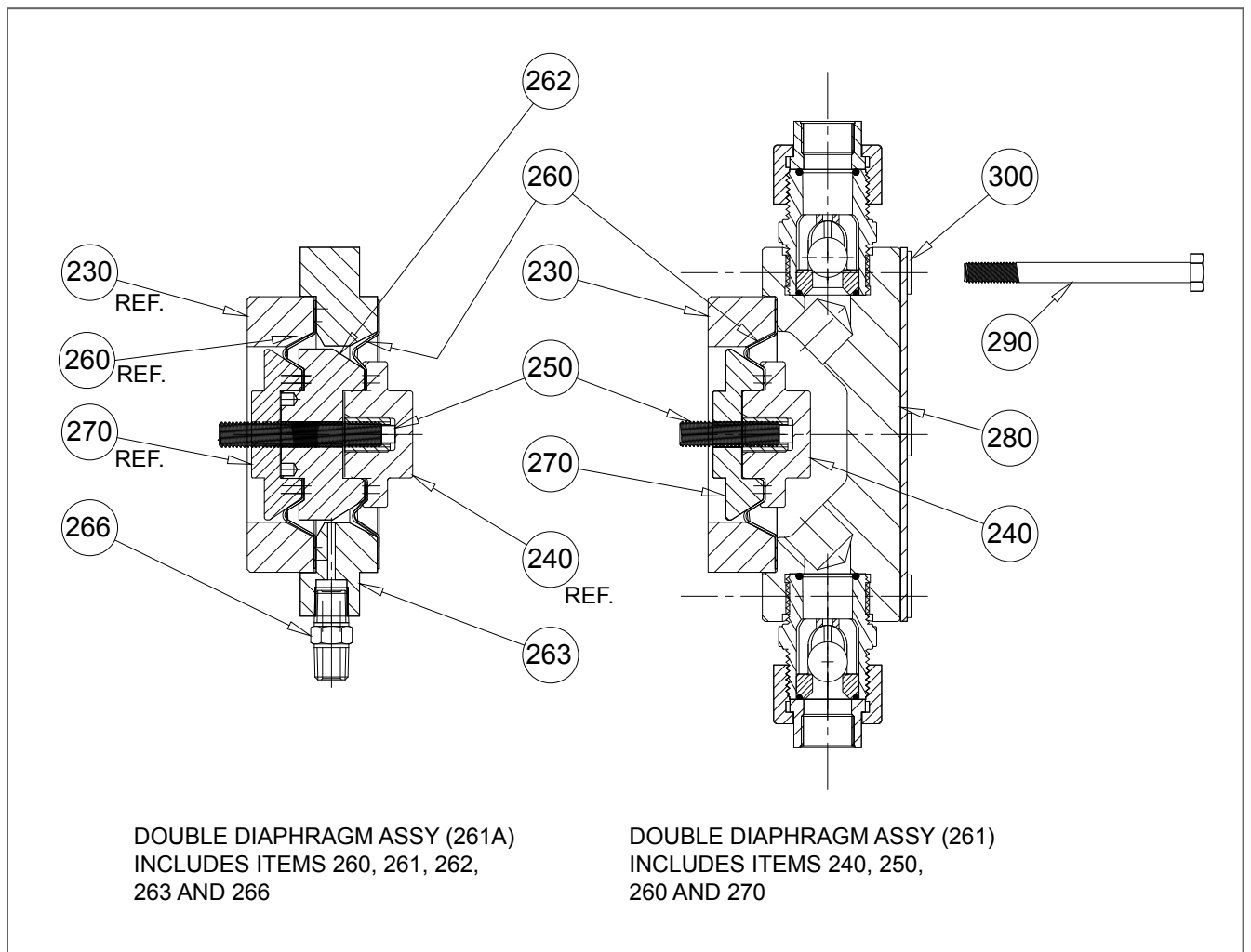

Figure 8. G5 Metallic Liquid End (DWG 102-1999-0008)

6.6 G5 METALLIC LIQUID END - STAINLESS STEEL- NPT

Model:

Liquid End:

G5

Material:

7

FIGURE NUMBER	ITEM NUMBER	DESCRIPTION	PART NUMBER	QTY	REFERENCE CODE
8	230	Diaphragm Support Ring	60035	1	
	240	Diaphragm Cap, Part of Item 261	60631	1	
	250	Set Screw, Dog Pt., M10 x 45 mm, Single Diaphragm, Part of Item 261	4350071284	1	
	250	Set Screw, Dog Pt., M10 x 70 mm, Double Diaphragm, Part of Item 261A	4350071334	1	
	260	Diaphragm, Part of Item 261	60618	1	
		Diaphragm, Part of Item 261A	60618	2	
	261	Diaphragm Assembly, (Replaceable Design, Consists of Items 240, 250, 260 and 270), See Note 1	3050976120	1	
	261A	Double Diaphragm Assembly, (Replaceable Design, Consists of Items 260, 261, 262, 263 and 266), See Note 2	60273	1	
	262	Double Diaphragm Spacer, PVC, Part of Item 261A	980367071	1	
	263	Double Diaphragm Intermediate Ring (Included in double diaphragm assembly Item 261A)	980366071	1	
	266	Hex Nipple 1/4 NPT connection, 316SS (Included in double diaphragm assembly, Item 261A)	60208	1	
	270	Diaphragm Support Nut, Part of Item 261	60632	1	
	280	Diaphragm Head	210760016	1	
	290	Hex Head Screw, M8 x 90, Single Diaphragm	4350035655	6	
	290	Hex Head Screw, M8 x 110, Double Diaphragm	4350001655	-	
	300	Flat Washer (M8)	4340005085	-	

Note 1:

Diaphragm Assembly (261) can be purchased assembled or items 240, 250, 260, and 270 can be purchased separately.

Note 2:

Double Diaphragm Assembly (261A) can be purchased assembled or items 260, 261, 262, 263 and 266 can be purchased separately.

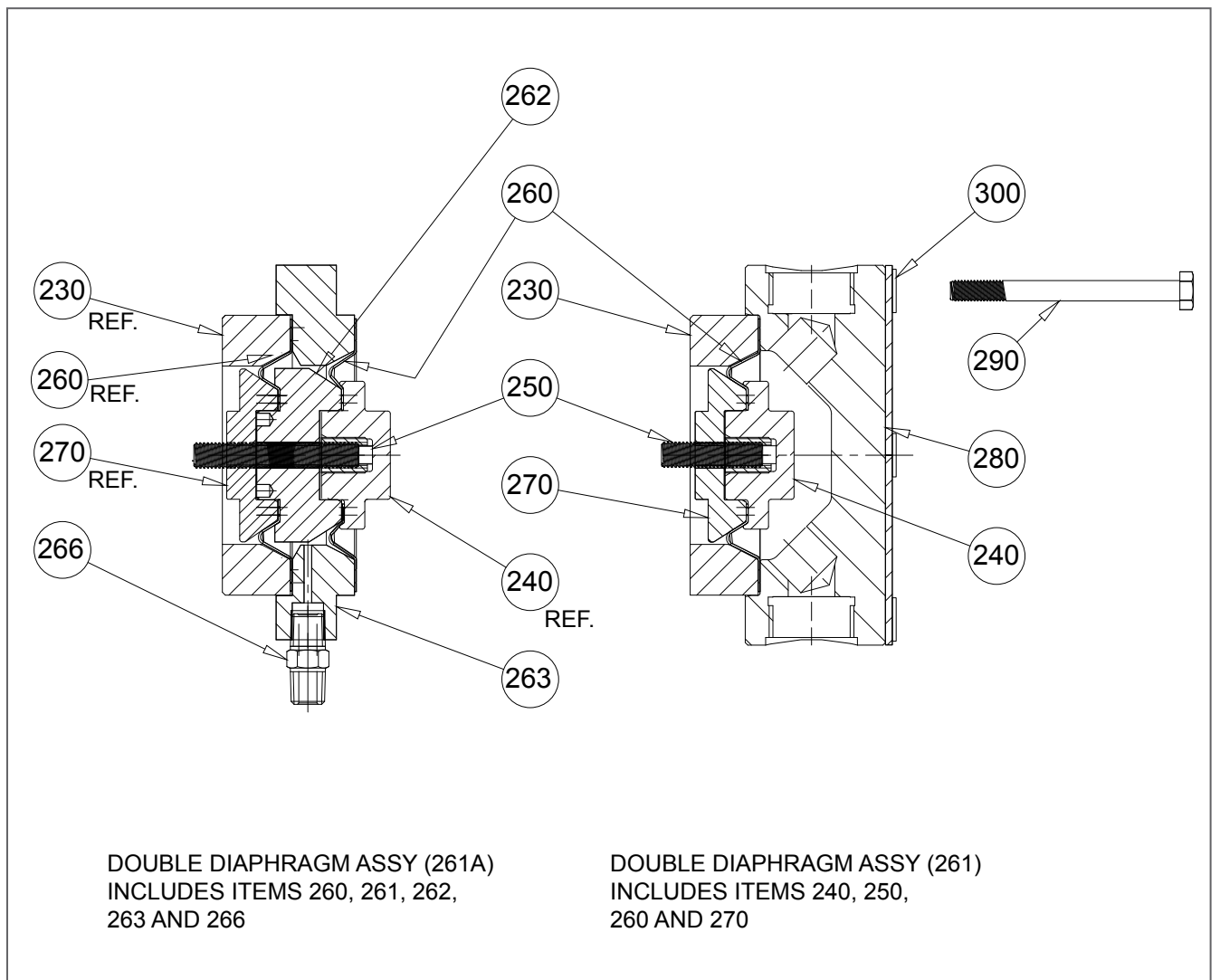

Figure 9. G6 Plastic Liquid End (DWG 102-1999-0009)

6.7 G6 PLASTIC LIQUID END

Model:

Liquid End:	Material:	Reference Code:
G6	8	A (PVC)
G6	4	B (BLACK POLY)
G6	2	C (PVDF)
G6	A	D (ACRYLIC) (Consult Factory)
G6	P	E (POLYMER)
G6	L	F (SLURRY)
G6	N	G (H ₂ SO ₄)

FIGURE NUMBER	ITEM NUMBER	DESCRIPTION	PART NUMBER	QTY	REFERENCE CODE
9	230	Diaphragm Support Ring	60070	1	
	240	Diaphragm Cap, Part of Item 261	60633	1	A, E, F, G
	240	Diaphragm Cap, Part of Item 261	60634	1	B
	240	Diaphragm Cap, Part of Item 261	60635	1	C
	250	Set Screw, Dog Pt., M10 x 45 mm, Single Diaphragm, Part of Item 261	4350071284	1	
	250	Set Screw, Dog Pt., M10 x 70 mm, Double Diaphragm Only, P/O 261A	4350071334	1	
	260	Diaphragm, Part of Item 261	60624	1	
		Diaphragm, Part of Item 261A	60624	2	
	261	Diaphragm Assembly, (Replaceable Design, Consists of Items 240, 250, 260 and 270), See Note 1	60151	1	A, E, F, G
	261	Diaphragm Assembly, (Replaceable Design, Consists of Items 240, 250, 260 and 270), See Note 1	3050976090	1	B
	261	Diaphragm Assembly, (Replaceable Design, Consists of Items 240, 250, 260 and 270), See Note 2	3050976230	1	C
	261A	Double Diaphragm Assy, (Replaceable Design, Consists of Items 260(2X), 261, 262, 263 and 266), See Note 2	60278	1	A, E, F, G
	261A	Double Diaphragm Assembly, (Replaceable Design, Consists of Items 260(2X), 261, 262, 263 and 266), See Note 2	60279	1	B
	261A	Double Diaphragm Assembly, (Replaceable Design, Consists of Items 260(2X), 261, 262, 263 and 266), See Note 2	60280	1	C
262	Double Diaphragm Spacer, PVC, Part of Item 261A	980369071	1		

G6 PLASTIC LIQUID END

FIGURE NUMBER	ITEM NUMBER	DESCRIPTION	PART NUMBER	QTY	REFERENCE CODE
9	263	Double Diaphragm Intermediate Ring (Included in double diaphragm assembly only, Item 261A)	980368071	1	
	266	Hex Nipple 1/4 NPT connection, 316SS (Included in double diaphragm assembly, Item 261A)	60208	1	
	270	Diaphragm Support Nut, Part of Item 261	60637	1	
	280	Diaphragm Head, PVC	60130	1	A, E, F, G
	280	Diaphragm Head, Black PP	60883	1	B
	280	Diaphragm Head, PVDF	60068	1	C
	290	Hex Head Screw, M8 x 90, Single Diaphragm	4350035655	6	
	290	Hex Head Screw, M8 x 130, Double Diaphragm	60206	6	
	300	Flat Washer (M8)	4340005085	6	
	300	Back-up Plate G5/G6	60754	1	B

Note 1:

Diaphragm Assembly (261) can be purchased assembled or items 240, 250, 260, and 270 can be purchased separately.

Note 2:

Double Diaphragm Assembly (261A) can be purchased assembled or items 260, 261, 262, 263 and 266 can be purchased separately.

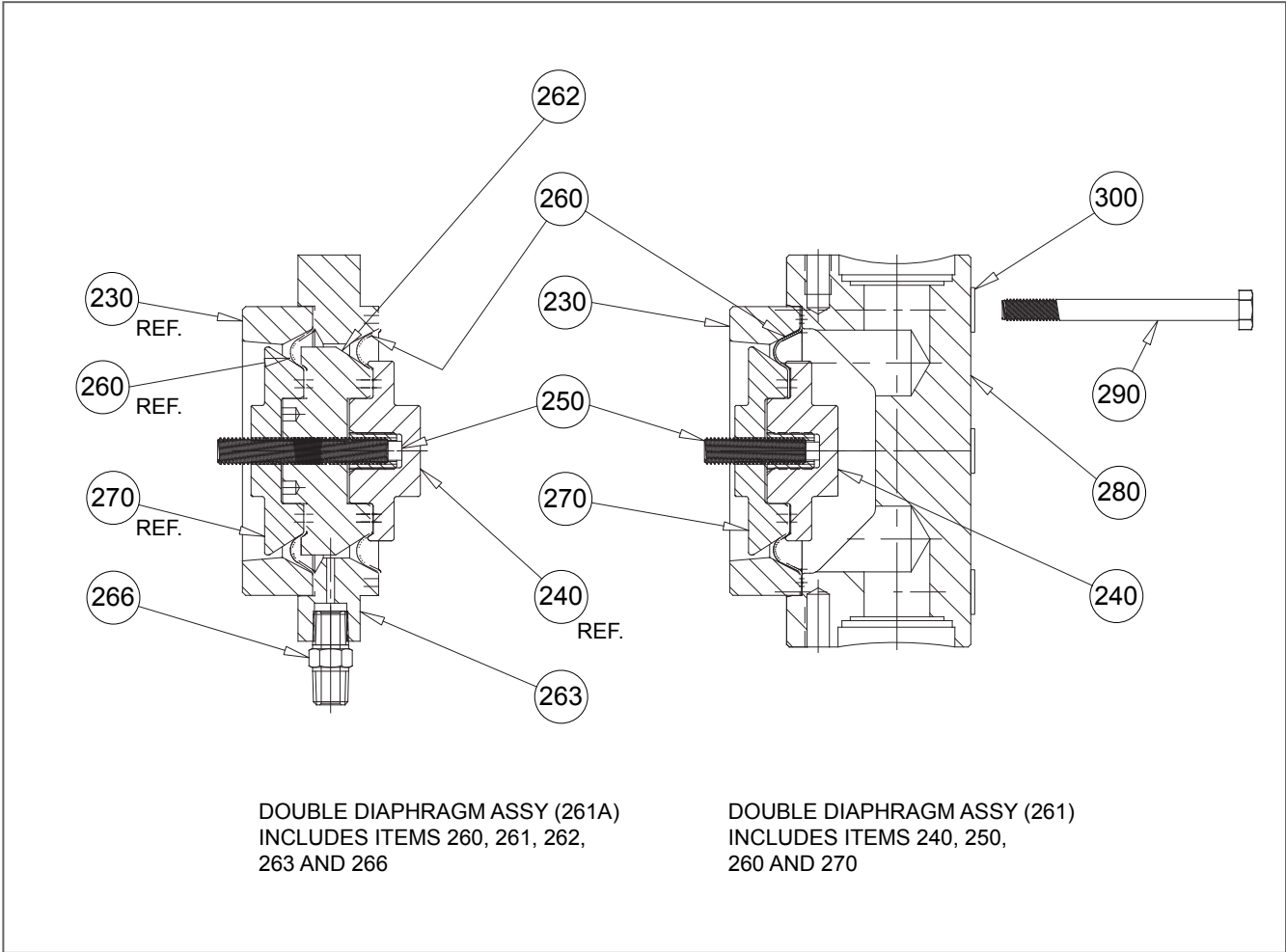

Figure 10. G6 Metallic Liquid End (DWG 102-1999-010)

6.8 G6 METALLIC LIQUID END - STAINLESS STEEL - NPT

Model:

Liquid End:

G6

Material:

7

FIGURE NUMBER	ITEM NUMBER	DESCRIPTION	PART NUMBER	QTY	REFERENCE CODE
10	230	Diaphragm Support Ring	60070	1	
	240	Diaphragm Cap, Part of Item 261	60636	1	
	250	Set Screw, Dog Pt., M10 x 45 mm, Single Diaphragm, Part of Item 261	4350071284	1	
	250	Set Screw, Dog Pt., M10 x 70 mm, Double Diaphragm, Part of Item 261A	4350071334	1	
	260	Diaphragm, Part of Item 261	60624	1	
		Diaphragm, Part of Item 261A	60624	2	
	261	Diaphragm Assembly, (Replaceable Design, Consists of Items 240, 250, 260, and 270), See Note 1	3050976320	1	
	261A	Double Diaphragm Assembly, (Replaceable Design, Consists of Items 260, 261, 262, 263 and 266), See Note 2	60277	1	
	262	Double Diaphragm Spacer, PVC, Part of Item 261A	980369071	1	
	263	Double Diaphragm Intermediate Ring (Included in double diaphragm assembly Item 261A)	980368071	1	
	266	Hex Nipple 1/4 NPT connection, 316SS (Included in double diaphragm assembly, Item 261A)	60208	1	
	270	Diaphragm Support Nut, Part of Item 261	60637	1	
	280	Diaphragm Head	210761016	1	
	290	Hex Head Screw, M8 x 90, Single Diaphragm	4350035655	6	
	290	Hex Head Screw, M8 x 130, Double Diaphragm	60206	6	
	300	Flat Washer (M8)	4340005085	6	

Note 1:

Diaphragm Assembly (261) can be purchased assembled or items 240, 250, 260, and 270 can be purchased separately.

Note 2:

Double Diaphragm Assembly (261A) can be purchased assembled or items 260, 261, 262, 263 and 266 can be purchased separately.

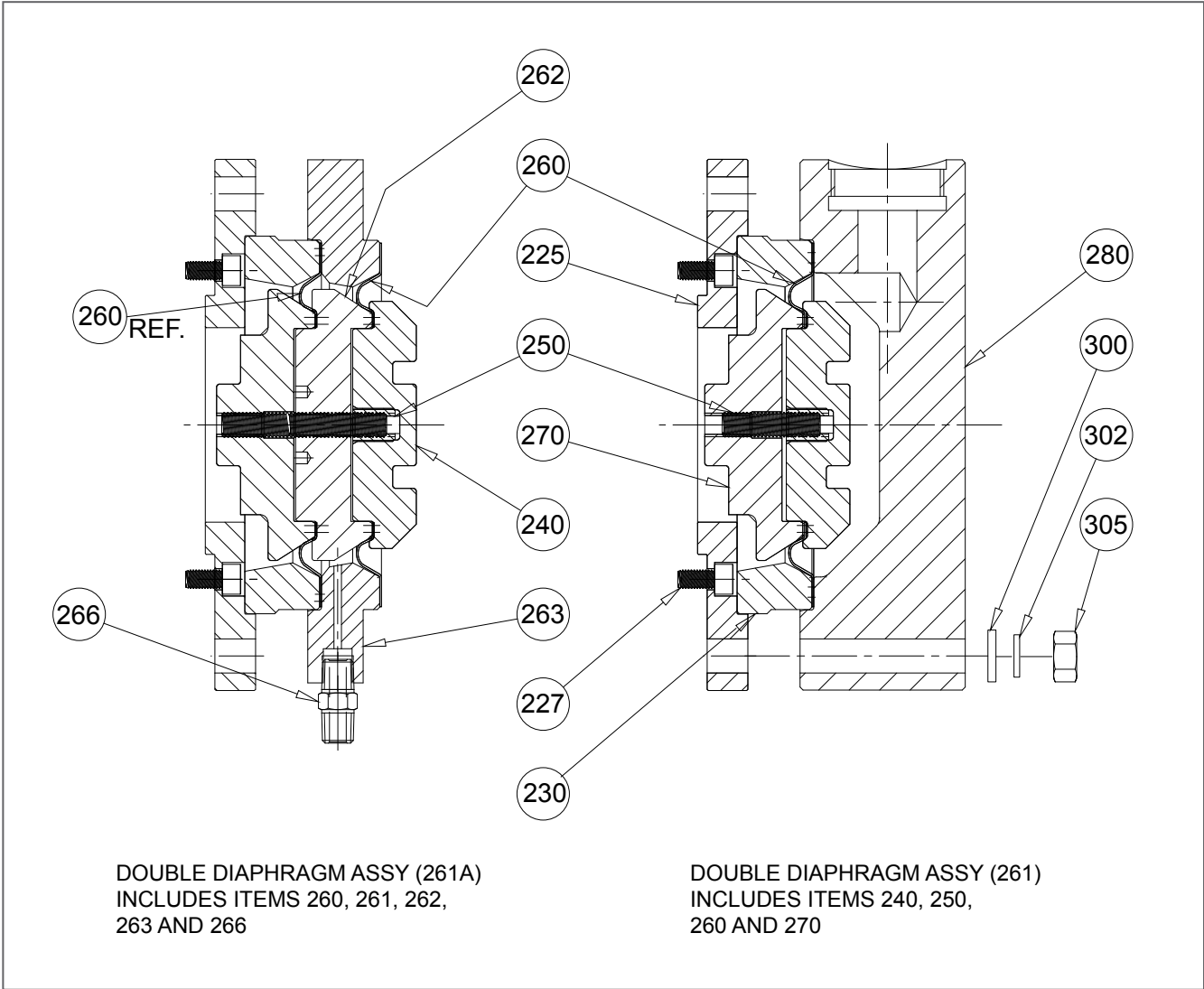

Figure 11. G7 Plastic Liquid End (DWG 102-1999-011)

6.9 G7 PLASTIC LIQUID END

Model:

Liquid End:	Material:	Reference Code:
G7	8	A (PVC)
G7	4	B (BLACK POLY)
G7	2	C (PVDF)
G7	A	D (ACRYLIC) (Consult Factory)
G7	P	E (POLYMER)
G7	L	F (SLURRY)
G7	N	G (H ₂ SO ₄)

FIGURE NUMBER	ITEM NUMBER	DESCRIPTION	PART NUMBER	QTY	REFERENCE CODE
11	225	Adapter Ring, Aluminum	60165	1	
	227	Socket Head Screw (M8 x 25 mm), Zinc PLT	4350003473	6	
	230	Diaphragm Support Ring	60159	1	
	240	Diaphragm Cap, Part of Item 261	60638	1	A, E, F, G
	240	Diaphragm Cap, Part of Item 261	60639	1	B
	240	Diaphragm Cap, Part of Item 261	60640	1	C
	250	Set Screw, Dog Pt., M10 x 70 mm, Single Diaphragm, Part of Item 261	4350071334	1	A, B, C, F
	250	Set Screw, Dog Pt., M10 x 90 mm, Double Diaphragm, Part of Item 261A	4350071374	1	A, B, C
	260	Diaphragm, Part of Item 261	60162	1	
		Diaphragm, Part of Item 261A	60162	2	
	261	Diaphragm Assembly, (Replaceable Design, Consists of Items 240, 250, 260 and 270), See Note 1	60226	1	A, F, G
	261	Diaphragm Assembly, (Replaceable Design, Consists of Items 240, 250, 260 and 270), See Note 1	60227	1	B
	261	Diaphragm Assembly, (Replaceable Design, Consists of Items 240, 250, 260 and 270), See Note 1	60229	1	C
	261A	Double Diaphragm Assembly, (Replaceable Design, Consists of Items 260(2X), 262, 263 and 266), See Note 2	60270	1	A, F, G
261A	Double Diaphragm Assembly, (Replaceable Design, Consists of Items 260(2X), 262, 263 and 266), See Note 2	60271	1	B	
261A	Double Diaphragm Assembly, (Replaceable Design, Consists of Items 260(2X), 262, 263 and 266), See Note 2	60272	1	C	

- Parts Not Illustrated

G7 PLASTIC LIQUID END

FIGURE NUMBER	ITEM NUMBER	DESCRIPTION	PART NUMBER	QTY	REFERENCE CODE
11	262	Double Diaphragm Spacer, PVC, Part of Item 261A	60232	1	A, B, C
	263	Double Diaphragm Intermediate Ring (Included in double diaphragm assembly Item 261A)	60233	1	A, B, C
	266	Hex Nipple 1/4 NPT connection, 316SS (Included in double diaphragm assembly, Item 261A)	60208	1	
	270	Diaphragm Support Nut, Part of Item 261	60642		
	280	Diaphragm Head	60171		A, E, F, G
	280	Diaphragm Head	60174		B, C
	290	Hex Head Screw, M8 x 90, Single Diaphragm	4350036035	6	A, B, C
	290	Hex Head Screw, M12 x 160, Double Diaphragm	4350036065	6	A, B, C
	300	Flat Washer (M8)	4340055073	6	

Note 1:

Diaphragm Assembly (261) can be purchased assembled or items 240, 250, 260, and 270 can be purchased separately.

Note 2:

Double Diaphragm Assembly (261A) can be purchased assembled or items 260, 261, 262, 263 and 270 can be purchased separately.

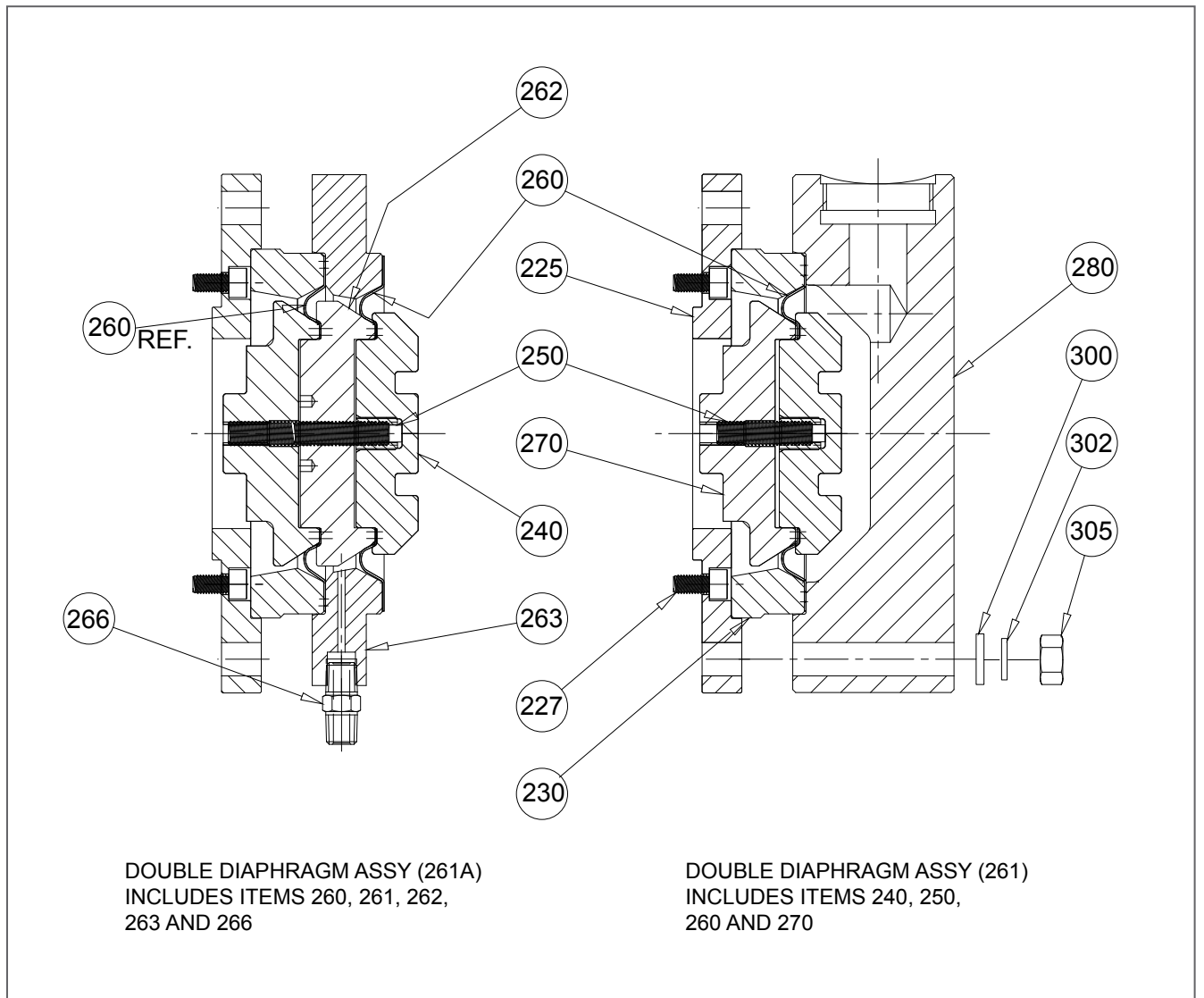

Figure 12. G7 Metallic Liquid End (DWG 102-1999-012)

6.10 G7 METALLIC LIQUID END - STAINLESS STEEL- NPT

Model:

Liquid End:

G7

Material:

7

FIGURE NUMBER	ITEM NUMBER	DESCRIPTION	PART NUMBER	QTY	REFERENCE CODE
12	225	Adapter Ring, Aluminum	60165	1	
	227	Socket Head Screw (M8 x 25 mm), Zinc PLT	4350003473	6	
	230	Diaphragm Support Ring	60159	1	
	240	Diaphragm Cap, Part of Item 261	60641	1	
	250	Set Screw, Dog Pt., M10 x 70 mm, Single Diaphragm, Part of Item 261	4350071334	1	
	250	Set Screw, Dog Pt., M10 x 90 mm, Double Diaphragm, Part of Item 261A	4350071374	1	
	260	Diaphragm, Part of Item 261	60162	1	
		Diaphragm, Part of Item 261A	60162	2	
	261	Diaphragm Assy, (Replaceable Design, Consists of Items 240, 250, 260 and 270), See Note 1	60228	1	
	261A	Double Diaphragm Assy, (Replaceable Design, Consists of Items 260, 261, 262, 263 and 266), See Note 2	60269	1	
	262	Double Diaphragm Spacer, PVC, Part of Item 261A	60232	1	
	263	Double Diaphragm Intermediate Ring (Included in double diaphragm assembly Item 261A)	60233	1	
	266	Hex Nipple 1/4 NPT connection, 316SS (Included in double diaphragm assembly, Item 261A)	60208	1	
	270	Diaphragm Support Nut, Part of Item 261	60642	1	
	280	Diaphragm Head	60180	1	
	290	Hex Head Screw, M12 x 130, Single Diaphragm	4350036035	6	
	290	Hex Head Screw, M12 x 160, Double Diaphragm	4350036065	6	
300	Flat Washer (M12)	4340055073	6		

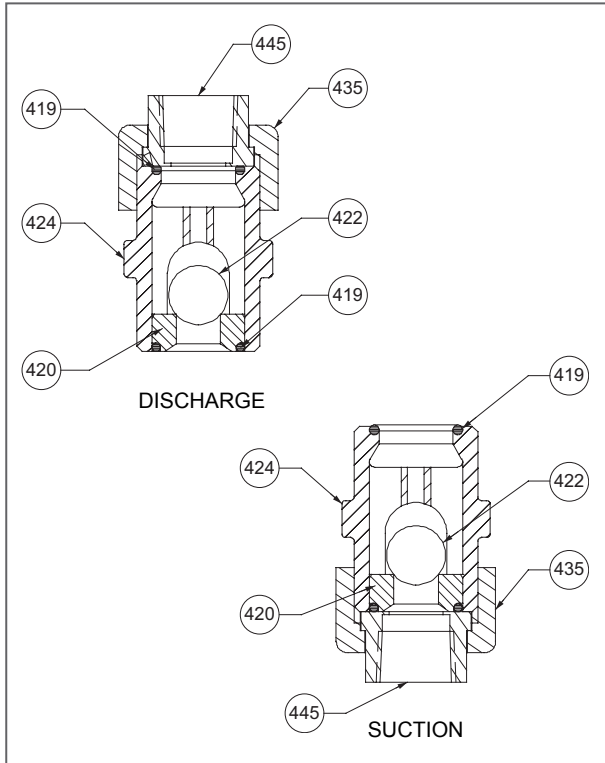

Figure 13A. Model G5 Plastic Check Valve Parts (Item Number 425)

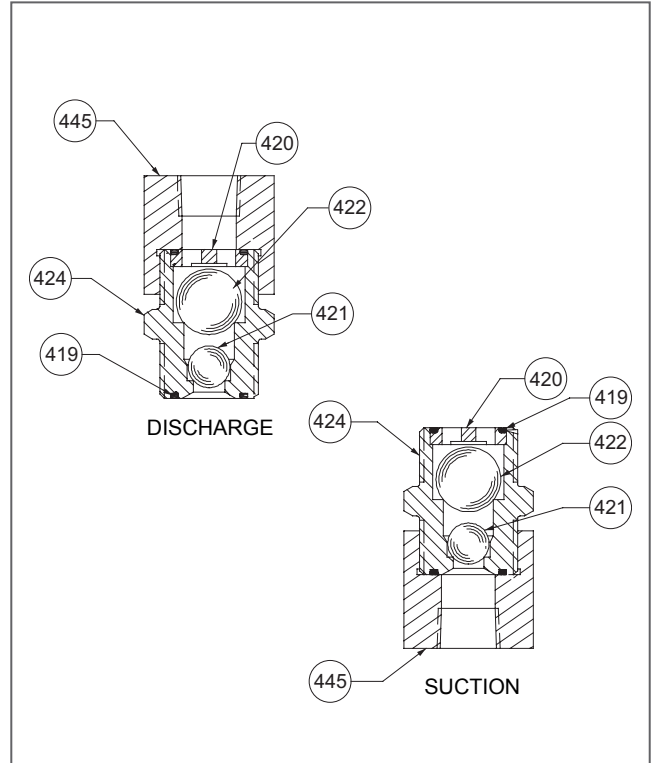

Figure 13B. Model G5 Metallic Check Valve Parts (Item Number 425)

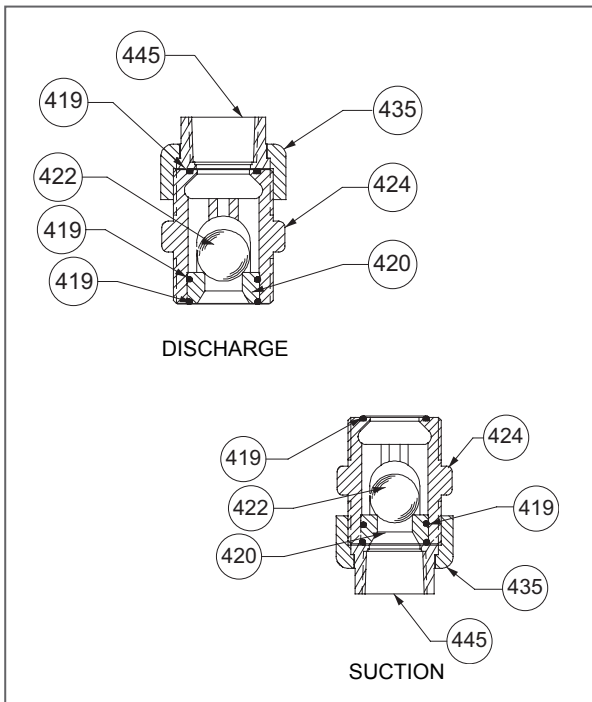

Figure 13C. Model G6 & G7 Plastic Check Valve Parts (Item Number 425)

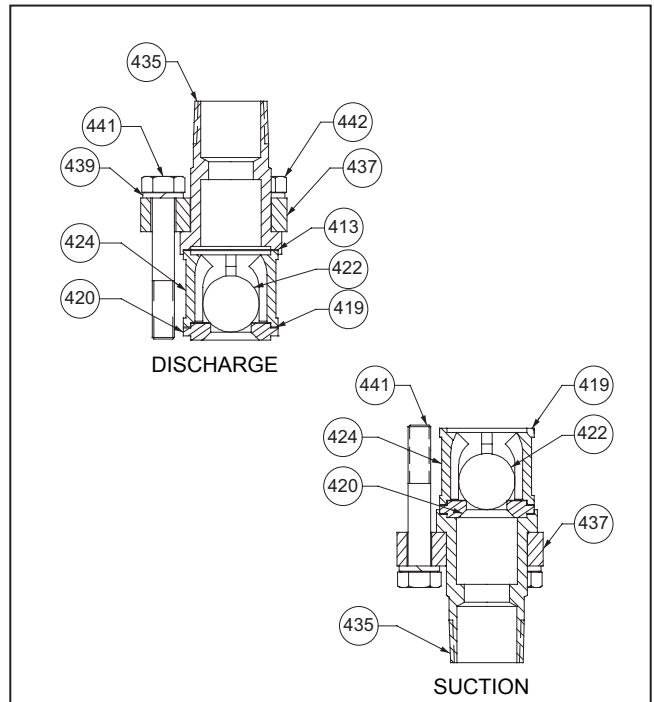

Figure 13D. Model G6 & G7 Metallic Check Valve Parts (Item Number 425)

Figure 13. (A to D) Check Valve Parts (DWG 102-1999-002)

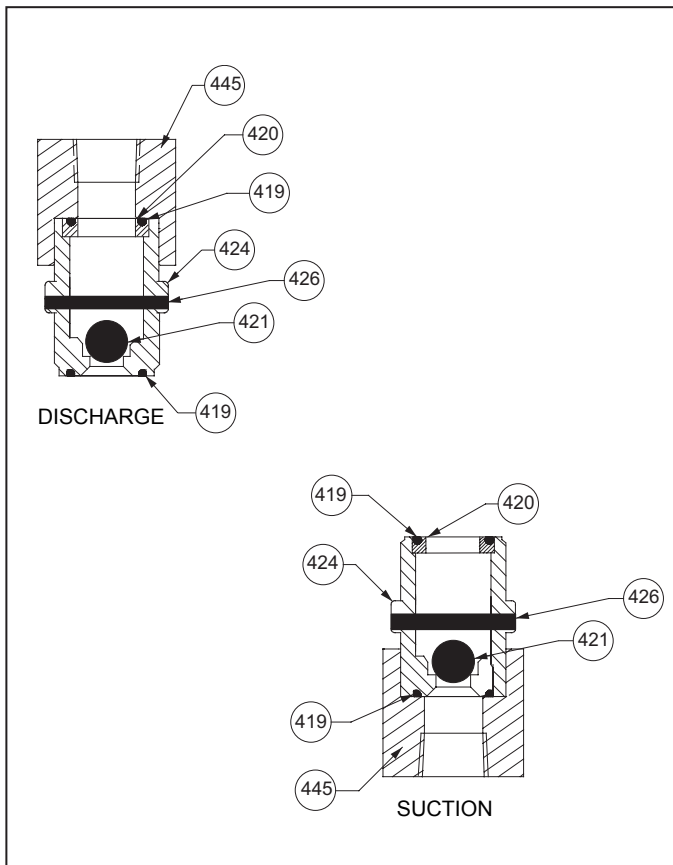

Figure 13E. Model G5 Slurry Check Valve Parts (Item Number 425)

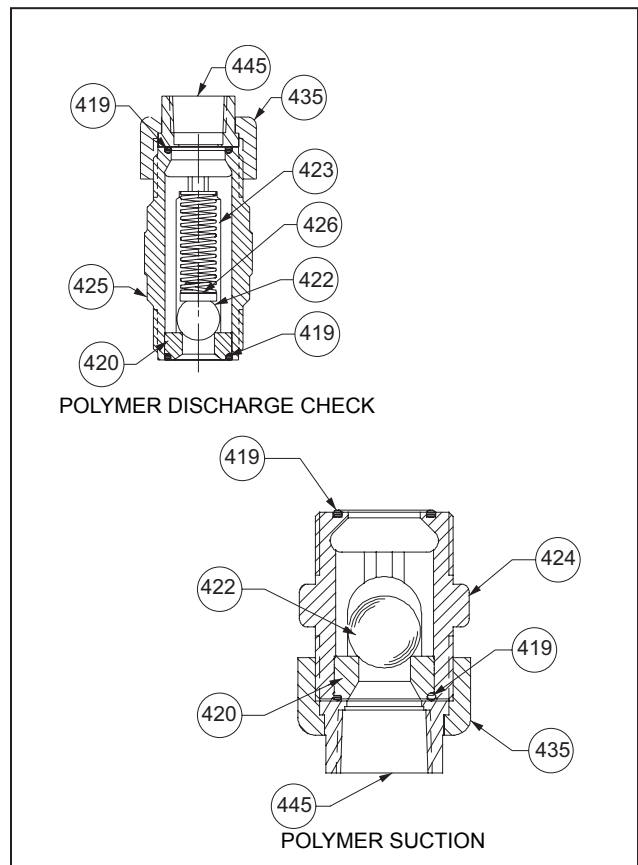

Figure 13F. Model G5, G6, and G7 Polymer Check Valve Parts (Item Number 425)

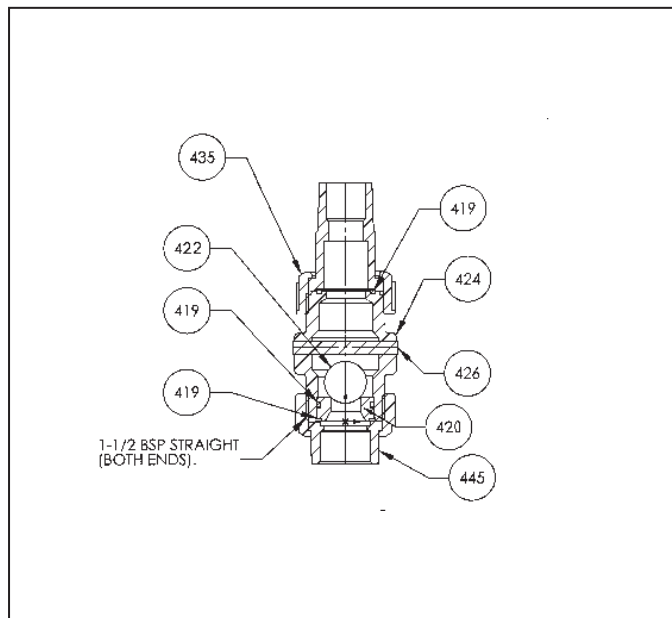

Figure 13G. Model G6 & G7 Slurry Check Valve Parts (Item Number 425)

Figure 13. (E to G) Check Valve Parts (DWG 102-1999-002)

6.11 CHECK VALVE PARTS

Model:

<u>Liquid End:</u>	<u>Material:</u>	<u>Reference Code:</u>
5	7 (316SS)	A1
5	8 (PVC)	A2
5	4 (BLK POLY)	A3
5	2 (PVDF)	A4
5	A (ACRYLIC)	A5
5	P (POLYMER)	A6
5	L (SLURRY)	A7
5	N (H ₂ SO ₄)	A8
6	7 (316SS)	B1
6	8 (PVC)	B2
6	4 (BLK POLY)	B3
6	2 (PVDF)	B4

Model:

<u>Liquid End:</u>	<u>Material:</u>	<u>Reference Code:</u>
6	A (ACRYLIC)	B5
6	P (POLYMER)	B6
6	L (SLURRY)	B7
6	N (H ₂ SO ₄)	B8
7	7 (316SS)	C1
7	8 (PVC)	C2
7	4 (BLK POLY)	C3
7	2 (PVDF)	C4
7	A (ACRYLIC)	C5
7	P (POLYMER)	C6
7	L (SLURRY)	C7
7	N (H ₂ SO ₄)	C8

FIGURE NUMBER	ITEM NUMBER	DESCRIPTION	PART NUMBER	QTY	REFERENCE CODE
13	419	O-ring, 2-117, Viton A	4080068075	4	A1, A2, A3, A6, A7, A8
	419	O-ring, 2-117, Teflex Parker	40348	4	A4
	419	Gasket, Teflon, 1 inch Ball, (See Note 3)	2250075275	6	B1, C1
	419	O-ring, 2-123, Viton A	4080068135	6	B2, B3, B6, B7, C2, C3, C6, C7, B8, C8
	419	O-ring, Teflex-V-123	60765	6	B4, C4
	420	Seat, (See Note 2)	920064016	2	A1
	420	Seat, 5/8 PVDF	2240173078	2	A2, A3, A4
	420	Seat, 5/8 UHMWPE	2240173073	2	A3
	420	Seat, PVC, Double Ball	920064071	2	A2
	420	Seat, 5/8 316SS	2240173016	2	A6
	420	Seat, 166mm 316SS	2240089016	2	B1, C1
	420	Seat, 1 inch Polyethylene	60240137073	2	B2, B3, C2, C3
	420	Seat, PVDF	60240137078	2	B4, C4
	420	Seat, 1 inch 316SS	240137016	2	B6, B7, C6, C7
	420	Seal, Ring 316SS	60819	2	A7
	420	Seat, 1 inch CA20	61216	2	B8, C8
	420	Seat, 5/8 CA20	60855	2	A8
	421	Ball, 14mm 316SS, (See Note 1 and 4)	60709	2	A1, A7
	421	Ball, 14mm Ceramic, Double Ball	4370000140	2	A2
	422	Ball, 22mm 316SS, (See Note 2)	60710	2	A1
422	Ball, 5/8 Ceramic	4070015171	2	A2, A3, A4	

- Parts Not Illustrated

CHECK VALVE PARTS

FIGURE NUMBER	ITEM NUMBER	DESCRIPTION	PART NUMBER	QTY	REFERENCE CODE
13	422	Ball, 5/8 PVC	4070170173	2	A2
	422	Ball, 7/8 Ceramic, Double Ball	4070015211	2	A2
	422	Ball, 5/8 CA20	4070014173	2	A2, A8
	422	Ball, 5/8 316SS	4070014172	2	A2, A6
	422	Ball, 1 inch 316SS	4070014232	2	B1, B6, B7, C1, C6, C7
	422	Ball, 1 inch Ceramic	4070015231	2	B2, B3, B4, C2, C3, C4
	422	Ball, 1 inch CA20	4070014233	2	B8, C8
	423	Seat, Seal, and Ball Set	(See Note 2)	2	A1
	423	Seat, Seal, and Ball Set	3050436322	2	B1, C1
	423	Seat, Seal, and Ball Set	3050879500	2	A2, A3
	423	Seat, Seal, and Ball Set	3050879700	2	A4
	423	Seat, Seal, and Ball Set	3050629500	2	B2, B3, C2, C3
	423	Seat, Seal, and Ball Set	3050629700	2	B4, C4
	423A	Spring Hastelloy, Polymer (Discharge)	800123026	1	A6
	423A	Spring Hastelloy, Polymer (Discharge)	60800083026	1	B6, C6
	424	Ball Guide, 316SS, (See Note 2)	210696016	2	A1
	424	Ball Guide, 316SS	2920052016	2	B1, C1
	424	Ball Guide, PVDF	60024	2	A2, A3, A4, A8
	424	Ball Guide, PVC	60030106071	2	B2, C2, C8
	424	Ball Guide, PP	30106070	2	B3, C3
	424	Ball Guide, PVDF	60030106078	2	B4, C4, B8
	424	Ball Guide, PVDF, Polymer (Suction)	60024	1	A6
	424	Ball Guide, PVC, Spring Loaded, Polymer (Discharge)	30156071	1	A6
	424	Ball Guide, PVC (Polymer Suction)	60030106071	1	B6, C6, C8
	424	Ball Guide, PVC Spring Loaded, Polymer (Discharge)	60030134071	1	B6, C6
	424	Ball Guide, Slurry, 316SS, (See Note 1 & 4)	60818	2	A7
	424	Ball Guide, Slurry, 316SS, (See Note 1 and 4)	61118	2	B7, C7
	424	Double Ball Guide, PVC	210696071	2	A2
	425	Check Valve Assembly (See Note 1 & 2)	3050876602	2	A1
	425	Check Valve Assembly (See Note 1)	3050583022	2	B1, C1
425	Check Valve Assembly (See Note 1)	3050870007	2	A2	
425	Check Valve Assembly (See Note 1)	3050629007	2	B2, C2	
425	Check Valve Assembly (See Note 1)	3050870009	2	A3	

- Parts Not Illustrated

CHECK VALVE PARTS

FIGURE NUMBER	ITEM NUMBER	DESCRIPTION	PART NUMBER	QTY	REFERENCE CODE
13	425	Check Valve Assembly (See Note 1)	3050629009	2	B3, C3
	425	Check Valve Assembly (See Note 1)	3050870008	2	A4
	425	Check Valve Assembly (See Note 1)	3050629008	2	B4, C4
	425	Check Valve Assembly(Discharge)	61645	1	B6, C6
	425	Check Valve Assembly(Suction)	61646	1	B6, C6
	425	Check Valve Assembly (See Note 1 & 4)	60827	2	A7
	424	Ball Guide, PP	30106070	2	B3, C3
	424	Ball Guide, PVDF	60030106078	2	B4, C4, B8
	424	Ball Guide, PVDF, Polymer (Suction)	60024	1	A6
	424	Ball Guide, PVC, Spring Loaded, Polymer (Discharge)	30156071	1	A6
	424	Ball Guide, PVC (Polymer Suction)	60030106071	1	B6, C6, C8
	424	Ball Guide, PVC Spring Loaded, Polymer (Discharge)	60030134071	1	B6, C6
	424	Ball Guide, Slurry, 316SS, (See Note 1 and 4)	60818	2	A7
	424	Ball Guide, Slurry, 316SS, (See Note 1 and 4)	61118	2	B7, C7
	424	Double Ball Guide, PVC	210696071	2	A2
	425	Check Valve Assembly	3050876602	2	A1
	425	Check Valve Assembly (See Note 1)	3050583022	2	B1, C1
	425	Check Valve Assembly (See Note 1)	3050870007	2	A2
	425	Check Valve Assembly (See Note 1)	3050629007	2	B2, C2
	425	Check Valve Assembly (See Note 1)	3050870009	2	A3
	425	Check Valve Assembly (See Note 1)	3050629009	2	B3, C3
	425	Check Valve Assembly (See Note 1)	3050870008	2	A4
	425	Check Valve Assembly (See Note 1)	3050629008	2	B4, C4
	425	Check Valve Assembly(Discharge)	61645	1	B6, C6
	425	Check Valve Assembly(Suction)	61646	1	B6, C6
	425	Check Valve Assembly (See Note 1 & 4)	60827	2	A7
	425	Check Valve Assembly	61277	2	B7, C7
	425	Ball Guide PVC For Spring (Discharge)	60030134071	1	B6, C6
	426	Poppet, PVDF	440090078	1	A6
	426	Dowel Pin, 316SS (See Note 4)	60820	2	A7
	426	Spring Seat, PVC	60440045071	1	B6, C6
	435	Union Nut, 1/2 PVC	4320236038	2	A2, A3, A4, A6, A7, A8
	435	Union Nut, PVC (1")	4320236058	2	B2, B3, B4, B6, B7, B8, C2, C3, C4, C6, C7, C8

- Parts Not Illustrated

CHECK VALVE PARTS

FIGURE NUMBER	ITEM NUMBER	DESCRIPTION	PART NUMBER	QTY	REFERENCE CODE
13	435	Connection (1" NPT Male)	450128116	2	B1, C1
	435	Connection (1" BSP Male)	450128016	2	B1, C1
	437	Valve Clamp, Steel	40215010	2	B1, B2, B3, B4, C1, C2, C3, C4
	439	Split Washer (M10) 304SS	4340009015	6	B1, B2, B3, B4, C1, C2, C3, C4
	441	Hex Head Screw (M10 x 65 mm) 304SS	4350035765	2	B1, B2, B3, B4, C1, C2, C3, C4
	442	Hex Head Screw (M10 x 75 mm) 304SS	4350035785	4	B1, B2, B3, B4, C1, C2, C3, C4
	445	Union End, PVC (1/2" NPT Female)	60117	2	A2, A3, A6, A7
	445	Union End (1" NPT)	60132	2	B2, B3, B6, B7, C2, C3, C6, C7, C8
	445	Union End (Metric Socket 15 x 20)	4320350028	2	A2, A3
	445	Union End (Metric Socket 25 x 32), PVC w/Solvent Weld	4320350008	2	B2, B3, C2, C3
	445	Union End (1/2" NPT)	60119	2	A4
	445	Union End (1/2" BSP)	60146	2	A4
	445	Union End (1" NPT)	60133	2	
	445	Union End (1" BSP)	60147	2	B4, C4
	445	Coupling, 316SS (1" BSP x 1/2" NPT)	60135	2	A1
	445	Coupling (1" BSP x 1/2" BSP)	450420016	2	A1
447	Elbow, PVC w/1" Tube	61395	2	B2, B4	

Note 1:

Item 425 (Check Valve Assembly) consists of items 424 (Ball Guide), 420 (Seat), 422 (Ball), 419 (Seal), and 421(Ball, Metallic Liquid End Codes 5 & C, 316SS and Slurry only).

Note 2:

G5 stainless check valves does not contain a removable ball seat (seat is integral to ball guide). Ball guide, ball and seal are not sold seperately. Replacement requires purchase of the complete check valve assembly (part # 305-0876-602).

Note 3:

Seal is a PTFE gasket for the G6, GD, G7, and GF stainless steel check valves. For all others the seal is an O-ring.

Note 4:

Check Valve Assembly (425, P/N 60827) does not contain a removable ball seat. Replacement of ball (421, P/N 60709), ball guide (424, P/N 60818) and dowel pin (426, P/N 60820) requires purchase of the complete check valve assembly.

- Parts Not Illustrated

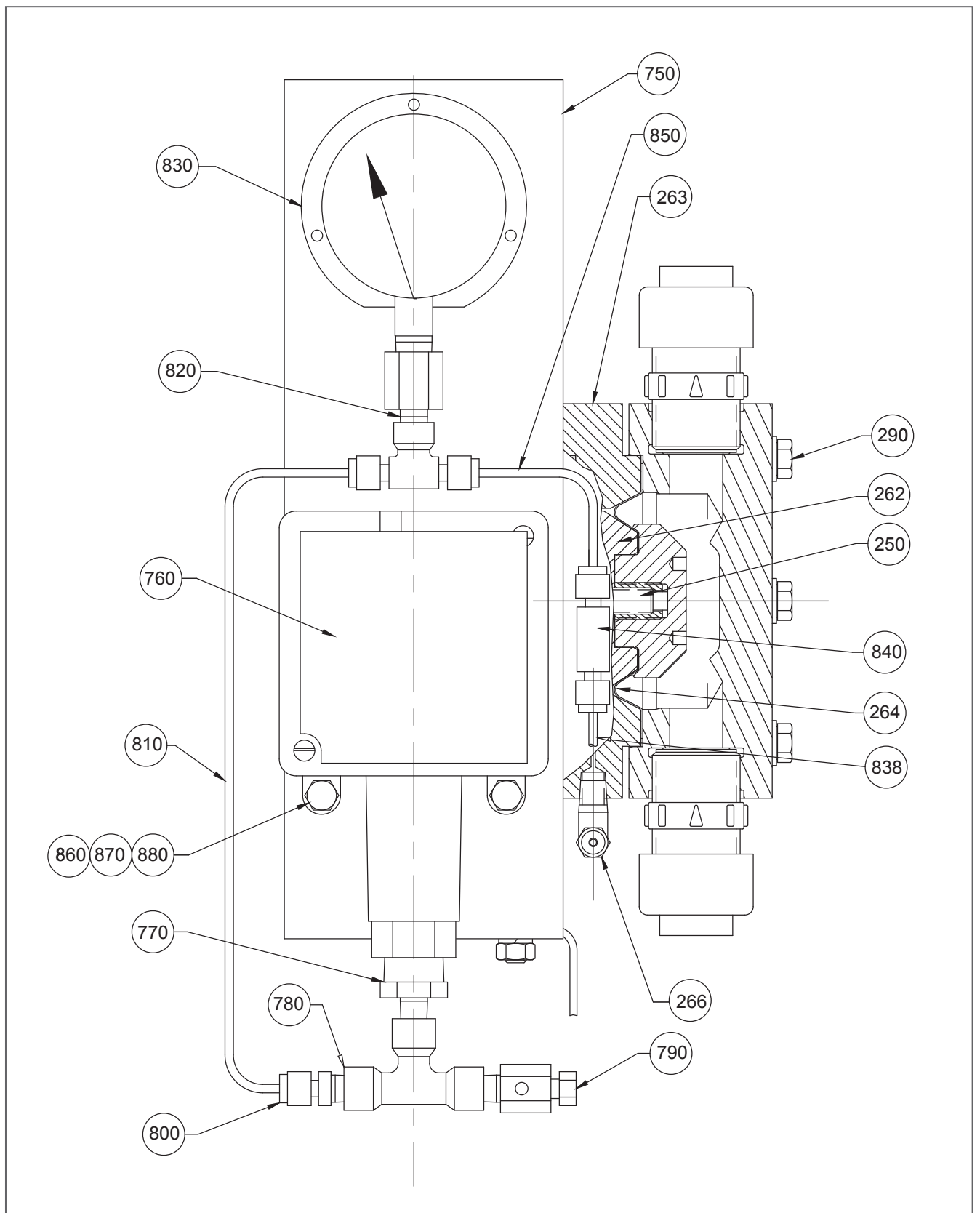

Figure 14. Leak Detection, Switch and Gauge (Optional) (DWG 10219990004)

6.12 LEAK DETECTION PARTS

<u>Old Model:</u>	<u>Model:</u>	<u>Code:</u>
G5, GC, 40	5	A
G6, GD, 60	6	B
G7, GF, 80	7	C

FIGURE NUMBER	ITEM NUMBER	DESCRIPTION	PART NUMBER	QTY	REFERENCE CODE
14	250	Set Screw, Dog Pt. M10X70mm -Steel	4350071334	1	A, B
	250	Set Screw, Dog Pt. M10X90mm - Steel	4350071374	1	C
	260	Diaphragm - Gylon	60618	1	A
	260	Diaphragm - Gylon	60624	1	B
	260	Diaphragm - Gylon	60162	1	C
	262	Leak Detector Spacer - PVC	980367071	1	A
	262	Leak Detector Spacer - PVC	980369071	1	B
	262	Leak Detector Spacer - PVC	60232	1	C
	263	Leak Detector Intermed. Ring - PVC	980366071	1	A
	263	Leak Detector Intermed. Ring - PVC	980368071	1	B
	263	Leak Detector Intermed. Ring - PVC	60233	1	C
	266	Male Elbow 1/8t X 1/4 NPT - 316SS	4020553042	1	
	290	Hex Head Screw M8X110mm - 304SS	4350001655	6	A
	290	Hex Head Screw M8X130mm - 304SS	60206	6	B
	290	Hex Head Screw M12X160mm - 304SS	4350036065	6	C
	750	Bracket	2040199006	1	
	760	Nema 4 Pres. Switch 5-30 PSI	4060388001	1	
	760	Nema 7 Pres. Switch 5-30 PSI	4060389001	1	
	770	Reducing Hex Nipple 1/2X1/8 NPT - 316SS	40064	1	
	780	Tee 1/8 NPT Female - 316SS	40062	2	
	790	Bleed Valve 1/8 NPT - 316SS	40063	1	
	800	Tubing Connector 1/8T X 1/8 NPT - 316SS	40061	3	
	810	Tubing, Gauge to Nema 4 Switch		1	
	810	Tubing, Gauge to Nema 7 Switch		1	
	820	Reducing Adapter 1/4F X 1/8M NPT - 316SS		1	
	830	Pres. Gauge 0-400 PSI (Dual Face) Flange Mt.	40066	1	
	838	Tubing, Check Valve to Pump	60984	1	A, B
	838	Tubing, Check Valve to Pump	60987	1	C
	840	Check Valve 1/8 Tube (1/3 PSI) - 316SS	40065	1	
	850	Tubing, Gauge to Check Valve - 316SS	60983	1	
	860	Hex Head Screw 1/4-20X3/4 - 18-8SS	4050016095	2	
	870	Spring Lock Washer 1/4" - 18-8SS	4040039022	2	
	880	Hex Nut 1/4-20NC - 18-8SS	4050064012	2	

- Parts Not Illustrated

We are a proud member of Accudyne Industries, a leading global provider of precision-engineered, process-critical, and technologically advanced flow control systems and industrial compressors. Delivering consistently high levels of performance, we enable customers in the most important industries and harshest environments around the world to accomplish their missions.



info@miltonroy.com
www.miltonroy.com



an Accudyne Industries brand

MacRoy® is a registered trademark of Milton Roy, LLC.
© 2015 Milton Roy, LLC.