

Compact. Powerful. Consistent Results.

The HELIMIX® top entry mixer is an efficient low-energy unit designed specifically for 275 gallon (1m³) and 330 gallon (1.25m³) Intermediate Bulk Containers (IBC). The contents in these containers may begin to separate during shipment with solid particles that settle or viscous products that become “frozen”.

The HELIMIX® mixer comes secured to a stainless steel 316L bridge support for quick mounting and removal from the IBC container. Fitted with a rotating collapsible impeller, the blades fold to 2.75 inches (70mm) to fit easily through the tank’s 5.5 inch (140mm) opening. After this quick installation, the HELIMIX® mixer is ready to begin the mixing process.



Applications:

- Homogenization
- Varnishes / Coatings
- Slurries
- Ink
- Chemical additives
- Liquid blending
- Coagulation
- Flocculation
- Syrup
- Milk
- Lime
- Additives
- Food additives
- Colors / Dyes
- And more...

Features & Benefits:

- Quick lead-times to keep your application up and running
- Homogenization and blending of any application (NOTE: not suitable for air injection, emulsion, dispersion, heating, chemical reaction)
- Sturdy stainless steel 316L lightweight bridge mounting ensures corrosion resistance for product longevity
- Mounting to the bridge via forklift, crane, or manually
- Several motor options (tri-phase or single phase or air motor compatible for proof area)
- Consistent results using variable low or high speed settings
- Start-stop button for simple and safe control

Specifications:

Available in several models to suit your application, Helimix® mixers offer several options including electric motor, air motor, low or high speed, start-stop button, and variable speed motors.

6 Drive / Blade Options

- Low or high speed
- Folding or marine impeller
- Electrical or air driven

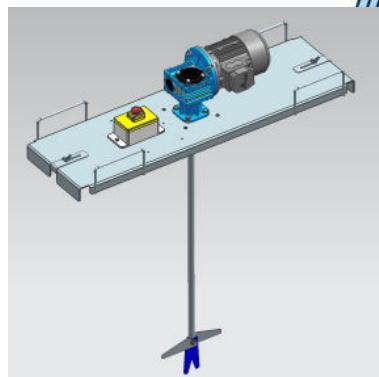

HELMIX Mixer type	ER1	ED1	ED2	PR1
Impeller	folding	1 Marine impeller 128	2 Marine propeller 128	folding
Rotation speed (rpm)	360	1200	1200	360
Rated power kW (hp)	0.5 (0.75)	0.5 (0.75)	0.5 (0.75)	0.56 (0.75) (compressed air)
M.O.C.	SS316L	SS316L	SS316L	SS316L
Maxi viscosity mPas/Cp	1000	300	1000	1000
Shaft length mm (inches)	812 (32)	812 (32)	812 (32)	812 (32)
Rotation in air	yes	yes	yes	yes

GAMME HELIMIX®

Agitateur pour conteneur IBC 1000 L / 1000 L IBC container mixer

Moteur /motor 0,37 kW
IP55,400v/50Hz/ 3 phases

Réducteur de vitesse / gear reducer
vitesse agitateur/ rotation speed : 290 rpm
sans entretien / no maintenance

Chassis support inox, avec anneaux de levage
SS support with lifting lugs
dimensions 1100 x 300

Arbre inox/ SS shaft
longueur maxi / maxi length : 800

Hélice à 2 pales retractables en inox /SS folding impeller
Ø 225, pales relevées /
Ø 70, pales pliées

Conteneur 1000 L IBC 1000x1200x1180 (NON FOURNI)
1000L IBC container 1000x1200x1180 (OUT OF SUPPLY)

La gamme Helimix est dédiée à l'agitation des liquides stockés dans un conteneur IBC. Le pompage de l'hélice élevé (> 300 m3/h), procure une agitation efficace des produits. L'hélice rétractable permet au repos une introduction aisée dans le conteneur, et en rotation d'avoir un grand diamètre d'agitation.

OPTIONS DISPONIBLES :

- moteur pneumatique
- variateur de vitesse
- vitesse rapide sans réducteur
- hélice non rétractable
- deux hélices sur l'arbre
- moteur monophasé 230v

Helimix range is dedicated to the stirring of bulk liquids in IBC containers. The high pumping flow (> 300 m3/h) generates an efficient mixing in all the bulk. The folding impeller allows an easy introduction into the IBC, and a large operating diameter.

OPTIONS :

- air driven mixer
- larger impeller xx mm dia.
- direct drive
- marine propeller
- two propellers on shaft
- monophase motor (230v)

fourni moteur nu sans coffret de démarrage supplied without electrical cabinet.		
DENSITE MAXI / MAXI SPECIFIC GRAVITY	1,2	
VISCOSITE / VISCOSITY	1000	mPas
Ø D'INTRO. DU MOBILE MINI / MINI OPENING	75	mm
POIDS / WEIGHT	20	kg

(dimensions. mm)

Helisem		
Type :	ER1/xxxxx	
REPERE CLIENT: / CUSTOMER ITEM:		Proposition N°/quoteN° :
N°		Rév.
Propriété exclusive de MRM - Communication et reproduction interdites. Plan non contractuel / Non binding drawing		date : 20/03/2015 par/by 0

* Dimensions valables pour le modèle standard sans option / Dimensions are only valid for standard type without option.

Ingersoll Rand Inc. (NYSE:IR), driven by an entrepreneurial spirit and ownership mindset, is committed to helping make life better. We provide innovative and mission-critical industrial, energy, medical and specialty vehicle products and services across 40+ respected brands designed to excel in even the most complex and harsh conditions where downtime is especially costly. Our employees connect to customers for life by delivering proven expertise, productivity and efficiency improvements. For more information, visit www.IRco.com.



miltonroy.com
miltonroymixing.com

Helimix is a registered trademark of Milton Roy, LLC.

©2018 Milton Roy, LLC.

6/2018