

rotork[®]

Keeping the World Flowing
for Future Generations

GT Range



Rack & Pinion Actuators for Rotary Valve Control

GT Range Rack & Pinion Actuators

GT range pneumatic rack & pinion actuators have been proven over a 30-year history of service in hundreds of thousands of installations, encompassing a variety of diverse applications.

There are a wide range of body sizes available in both double-acting and spring-return configurations. Units can be easily changed from one to the other – even in the field. In addition to the usual 90 degree rotation, 120, 180, and 240 rotations are also available. All models incorporate an anti-blowout design.

Many options are available to optimise the actuator for particular applications. Options include high- and low-temperature versions, anti-corrosion materials and treatments, valve mounting kits, and declutchable manual gear overrides.

We can also supply actuator control and indication components for virtually any functional requirement and installation environment. Accessory mounting conforms to NAMUR specifications and valve mounting dimensions are per ISO 5211 standards.

Rotork can provide a variety of additional services including application engineering, installation and retrofit, as well as maintenance and repair by factory-trained service personnel.

With superior design, material specification, manufacturing precision, and an industry-best global sales and service support network, Rotork GT range actuators are the wisest choice for any rack & pinion valve actuation requirement.

Every Rotork product is built to provide long and efficient service with a minimum of maintenance. The design, engineering and materials used in the construction ensure optimum performance even in the harshest of environments.

As a global leader in valve actuation technology, we provide a comprehensive range of valve actuators, controls and associated equipment. We also supply a variety of valve actuator services including commissioning, preventive maintenance and retrofit solutions.

Rotork specialises in the production and support of fluid power actuators and control systems. We are dedicated to providing the marketplace with the latest technology, consistently high quality, innovative design, excellent reliability and superior performance.

We maintain dedicated engineering groups for Applications, Product Improvement and New Product Development so that our customers can gain all the benefits that ever advancing technologies have to offer and to ensure our efforts are in step with the continually evolving needs of our customers.

Most importantly, we have a long-standing commitment to meeting the special needs of a wide range of applications including: oil and gas exploration and transportation; municipal water and wastewater treatment; power generation; and the chemical and process industries.

With over 60 years of engineering and manufacturing expertise, we have tens of thousands of successful valve actuator installations throughout the world.



Fitting Accessories

The Right Accessory Solutions

Valves and actuators only perform as well as the solution is engineered. With decades of experience engineering fluid power valve automation for a multitude of applications and markets, you can depend on Rotork to provide a reliable and safe automation solution to meet your requirements.

In addition to the valve actuator itself, Rotork manufactures a wide range of precision flow control and accessory products as well as a variety of gearboxes and override options. We have designs to withstand the challenges of any valve operating environment.



Inside The GT Actuator

Every Rotork actuator is built to provide long and efficient service with minimum maintenance. The design, engineering and materials used in their construction ensure optimum performance even in the harshest of environments.

Supply	Filtered air ISO 8573-1:2010	
Optional:	Others on request	
Operating Pressure	29 to 145 psi	(2 to 10 bar)
Torque Output	21 to 135,400 lbf.in	(2.4 to 15,300 Nm)

Temperature Ranges

Standard:	-58 to +158 °F	(-50 to +70 °C)
	NBR o-ring, Delrin guide	
Optional:	+5 to +320 °F	(-15 to +160 °C)
	Viton o-ring, IXEF guide	
Optional:	-76 to +392 °F	(-60 to +200 °C)
	Silicone o-ring, PTFE guide	

Mounting Standards

Air supply:	VDI/VDE 3845, NAMUR
	1/8" NPT
	(sizes from 33 to 92)
	1/4" NPT
	(sizes from 110 to 302)

Accessories: VDI/ VDE 3845, NAMUR

Valve interface: ISO 5211

Valve shaft interface: ISO 5211 double square

Other interface options available, see page 9.

Rotation 90°

Optional: 120°, 180°, 240°, or custom angles

Stroke Adjustment -5° to +5° from 90° position
Single- or dual-direction travel stops acting upon the piston(s)¹

Optional: Extended travel adjustment on the opening stroke is available with installation of a longer stop screw

Materials

Body:	Anodised aluminium ASTM 6063
Optional:	Stainless steel AISI 316 (limited sizes) or epoxy paint
Pinion:	Carbon steel EN 11SMnPb3 electroless nickel plated
Optional:	Stainless steel AISI 316
Pistons:	Die-cast aluminium UNI EN1706
End caps:	Die-cast aluminium UNI EN1706, EN AC- 46100, epoxy paint (black RAL 9005)
Spring cartridge:	Carbon steel, epoxy paint

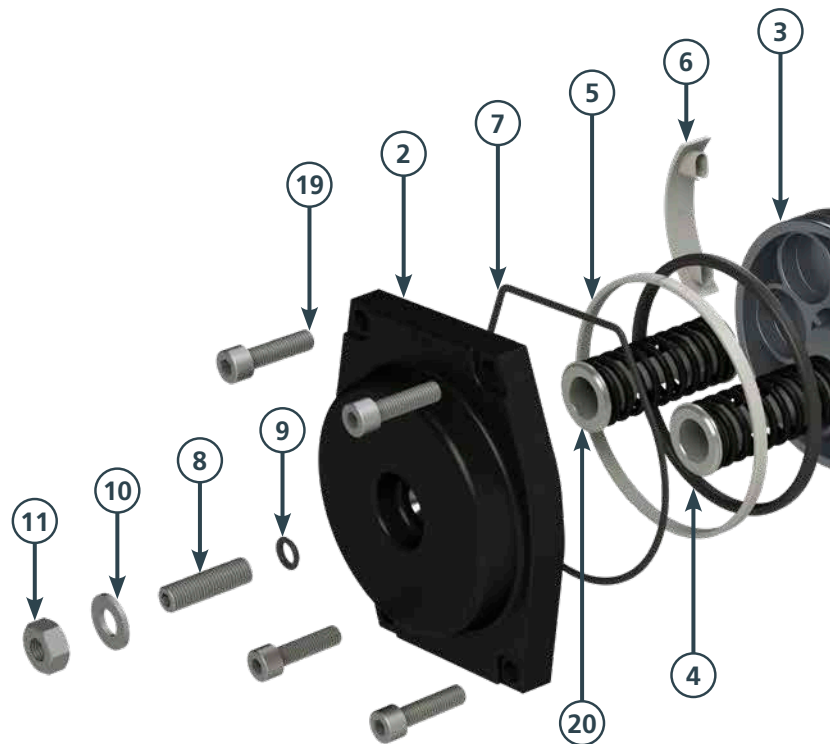

Optional Surface Treatments

- Anodised body, blue epoxy-painted end caps (RAL 5015)
- Hard anodised body, blue epoxy-painted end caps (RAL 5015)
- Hard anodised body, black epoxy-painted end caps (RAL 9005)
- Hard anodised body, end caps, and pistons
- Duraflon PTFE over anodised or hard-anodised body
- Polyester powder coat over anodised body
- FDA compliant epoxy polyester paint over anodised body
- Polyurethane Resin ISO 12944-6 over anodised body
- Plastcoat PPA571 ISO 12944-6 body and end caps

Contact Rotork with other requirements.

Inside The GT Actuator

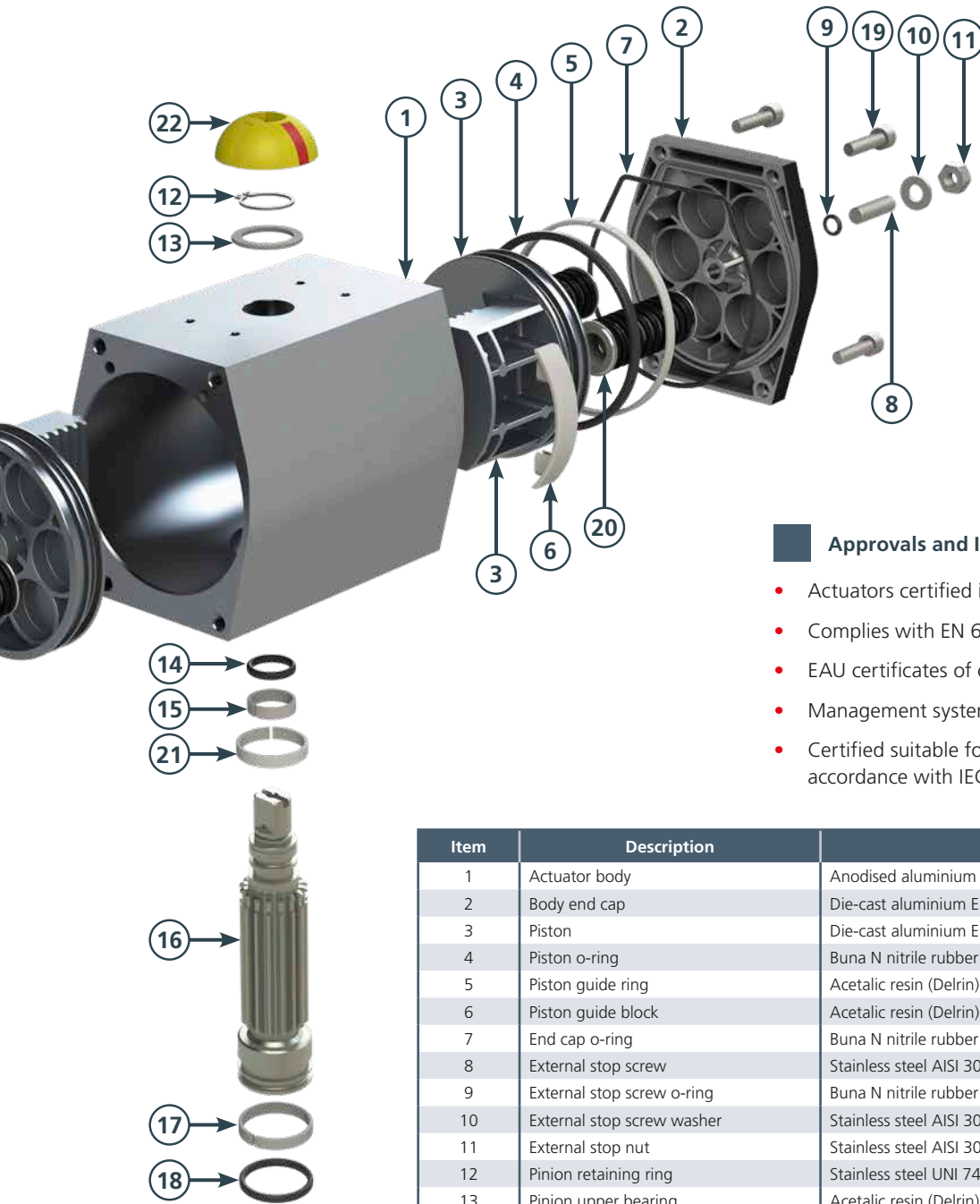

Approvals and Industry Standards

- Actuators certified in accordance with 2014/34/EU
- Complies with EN 60529 (1991) + (A1:2000) for IP66M
- EAU certificates of conformity
- Management system in accordance with ISO 9001:2015
- Certified suitable for use at SIL3 as a single device in accordance with IEC 61508

Item	Description	Material	Quantity
1	Actuator body	Anodised aluminium EN AW6063	1
2	Body end cap	Die-cast aluminium EN AC-46100	2
3	Piston	Die-cast aluminium EN AC-46100	2
4	Piston o-ring	Buna N nitrile rubber	2
5	Piston guide ring	Acetalic resin (Delrin)	2
6	Piston guide block	Acetalic resin (Delrin)	2
7	End cap o-ring	Buna N nitrile rubber	2
8	External stop screw	Stainless steel AISI 304	2
9	External stop screw o-ring	Buna N nitrile rubber	2
10	External stop screw washer	Stainless steel AISI 304	2
11	External stop nut	Stainless steel AISI 304	2
12	Pinion retaining ring	Stainless steel UNI 7435	1
13	Pinion upper bearing	Acetalic resin (Delrin)	1
14	Pinion upper o-ring	Buna N nitrile rubber	1
15	Pinion upper guide bearing	Acetalic resin (Delrin)	1
16	Pinion	Carbon steel EN 11SMnPb3 (electroless nickel plated)	1
17	Pinion lower guide bearing	Acetalic resin (Delrin)	1
18	Pinion lower o-ring	Buna N nitrile rubber	1
19	End cap retaining screws	Stainless steel AISI 304	8
20	Spring cartridge	Steel (epoxy painted)	0-12
21	Anti-blowout ring	Polyarylamide	1
22	Position indicator	Nylon 6	1

1. GT range actuators are available with either single- or dual-direction of travel stop adjustment, except on the smallest sizes, 33, 34, 43, and 44 which do not have any travel adjustment in the standard version. Outboard stop adjustment is +/- 5° (e.g. 85° - 95°). Inboard stop adjustment is +5°/-25°.

The illustration and parts list above depict an actuator with single-direction travel stop adjustment, standard temperature build.

Torque Output Data

Double-Acting Actuators

Model	Pneumatic Torque (lbf.in)						
	30 psi	40 psi	60 psi	80 psi	100 psi	120 psi	140 psi
33, 34	19	26	39	52	65	78	91
43, 44	43	57	86	115	143	172	201
52	71	95	143	190	238	286	333
63	106	141	212	283	354	425	496
75	183	244	366	489	611	733	855
83	266	354	531	708	886	1,063	1,240
92	366	488	732	977	1,221	1,465	1,709
110	531	708	1,062	1,416	1,770	2,124	2,478
118	787	1,050	1,574	2,100	2,624	3,149	3,675
127	1,062	1,416	2,124	2,832	3,540	4,248	4,956
143	1,702	2,270	3,405	4,541	5,676	6,811	7,946
160	2,105	2,808	4,211	5,615	7,018	8,423	9,826
190	3,662	4,883	7,324	9,765	12,207	14,648	17,090
210	4,394	5,859	8,788	11,718	14,647	17,577	20,506
253	6,321	8,428	12,642	16,855	21,069	25,283	29,497
254	8,423	11,231	16,846	22,462	28,077	33,693	39,308
255	10,620	14,160	21,240	28,320	35,400	42,481	49,560
300	14,646	19,528	29,292	39,055	48,819	58,583	68,347
302	28,008	37,343	56,015	74,687	93,358	112,030	130,702

Single-Acting Actuators

Model	Springs	Spring Torque (lbf.in)		Pneumatic Torque (lbf.in)													
				30 psi		40 psi		60 psi		80 psi		100 psi		120 psi		140 psi	
		0°	90°	0°	90°	0°	90°	0°	90°	0°	90°	0°	90°	0°	90°	0°	90°
43, 44	2	15	22	28	20	42	34	71	63	99	91	128	120	156	148	185	177
	4	30	45	-	-	27	11	55	40	84	68	113	97	141	126	170	154
	6	45	67	-	-	-	-	-	-	69	46	97	74	126	103	155	131
	8	59	90	-	-	-	-	-	-	-	-	82	51	111	80	139	108
52	2	17	28	54	43	78	66	126	114	173	162	221	209	268	257	316	304
	4	34	56	37	14	61	38	108	85	156	133	204	180	251	228	299	276
	6	51	85	-	-	-	-	91	56	139	104	186	152	234	199	281	247
	8	68	113	-	-	-	-	74	28	121	75	169	123	217	171	264	218
	10	85	141	-	-	-	-	-	-	104	47	152	94	199	142	247	189
	12	101	169	-	-	-	-	-	-	-	-	135	65	182	113	230	161
63	2	27	39	79	66	114	102	185	172	256	243	327	314	398	385	468	456
	4	53	78	52	26	87	62	158	133	229	203	300	274	371	345	441	416
	6	80	117	-	-	-	-	131	93	202	163	273	234	343	305	414	376
	8	106	157	-	-	-	-	104	53	175	124	245	194	316	265	387	336
	10	133	196	-	-	-	-	-	-	147	84	218	154	289	225	360	296
	12	160	235	-	-	-	-	-	-	120	44	191	115	262	185	333	256
75	2	46	70	136	111	197	172	319	294	441	416	563	538	685	661	807	783
	4	93	141	89	39	150	100	272	222	394	344	516	467	638	589	760	711
	6	139	211	-	-	102	28	224	151	346	273	468	395	591	517	713	639
	8	185	282	-	-	-	-	177	79	299	201	421	323	543	445	665	567
	10	232	352	-	-	-	-	-	-	252	129	374	251	496	373	618	495
	12	278	423	-	-	-	-	-	-	205	57	327	179	449	301	571	423
83	2	64	99	200	164	289	253	466	430	643	607	820	784	997	961	1,174	1,138
	4	128	198	135	63	223	152	400	329	577	506	754	683	931	860	1,108	1,037
	6	192	297	-	-	158	51	335	228	512	405	689	582	866	759	1,043	936
	8	256	396	-	-	-	-	270	127	447	304	624	481	801	658	978	835
	10	320	495	-	-	-	-	205	26	382	203	559	380	736	557	913	734
	12	384	594	-	-	-	-	-	-	316	102	493	279	670	456	847	633
92	2	81	127	284	237	406	359	650	603	894	847	1,138	1,091	1,383	1,335	1,627	1,579
	4	161	254	202	107	324	229	568	473	812	718	1,056	962	1,300	1,206	1,545	1,450
	6	242	381	-	-	242	100	486	344	730	588	974	832	1,218	1,076	1,462	1,320
	8	322	508	-	-	-	-	404	214	648	459	892	703	1,136	947	1,380	1,191
	10	403	635	-	-	-	-	322	85	566	329	810	573	1,054	817	1,298	1,061
	12	483	762	-	-	-	-	-	-	484	200	728	444	972	688	1,216	932

Torque Output Data

Single-Acting Actuators *continued*

Model	Springs	Spring Torque (lbf.in)		Pneumatic Torque (lbf.in)													
				30 psi		40 psi		60 psi		80 psi		100 psi		120 psi		140 psi	
		0°	90°	0°	90°	0°	90°	0°	90°	0°	90°	0°	90°	0°	90°	0°	90°
110	2	140	210	388	317	565	494	919	848	1,273	1,202	1,627	1,556	1,981	1,910	2,335	2,264
	4	280	420	246	103	423	280	777	634	1,131	988	1,485	1,342	1,839	1,696	2,193	2,050
	6	420	629	-	-	280	66	634	420	988	774	1,342	1,128	1,696	1,482	2,050	1,836
	8	560	839	-	-	-	-	491	206	845	560	1,199	914	1,553	1,268	1,907	1,622
	10	699	1,049	-	-	-	-	-	-	703	346	1,057	700	1,410	1,054	1,764	1,408
	12	839	1,259	-	-	-	-	-	-	560	132	914	486	1,268	840	1,622	1,194
118	2	188	323	595	458	858	721	1,383	1,246	1,908	1,770	2,433	2,295	2,957	2,820	3,482	3,345
	4	376	645	404	129	666	392	1,191	916	1,716	1,441	2,241	1,966	2,766	2,491	3,290	3,016
	6	564	968			474	62	999	587	1,524	1,112	2,049	1,637	2,574	2,162	3,099	2,687
	8	752	1,291					807	258	1,332	783	1,857	1,308	2,382	1,833	2,907	2,358
	10	940	1,613							1,140	454	1,665	979	2,190	1,504	2,715	2,029
	12	1,128	1,936							949	125	1,473	650	1,998	1,175	2,523	1,699
127	2	265	432	791	622	1,145	976	1,853	1,684	2,561	2,391	3,269	3,099	3,977	3,807	4,685	4,515
	4	531	863	521	181	875	535	1,583	1,243	2,291	1,951	2,998	2,659	3,706	3,367	4,414	4,075
	6	796	1,295			604	95	1,312	803	2,020	1,511	2,728	2,219	3,436	2,927	4,144	3,635
	8	1,062	1,727					1,041	362	1,749	1,070	2,457	1,778	3,165	2,486	3,873	3,194
	10	1,327	2,159							1,478	630	2,186	1,338	2,894	2,046	3,602	2,754
	12	1,592	2,590							1,208	190	1,916	898	2,624	1,606	3,332	2,313
143	2	425	610	1,269	1,081	1,836	1,648	2,972	2,784	4,107	3,919	5,242	5,054	6,377	6,189	7,512	7,324
	4	851	1,219	835	459	1,403	1,027	2,538	2,162	3,673	3,297	4,808	4,432	5,943	5,567	7,079	6,703
	6	1,276	1,829			969	405	2,104	1,540	3,239	2,675	4,374	3,810	5,509	4,945	6,645	6,081
	8	1,702	2,439					1,670	918	2,805	2,053	3,940	3,188	5,076	4,324	6,211	5,459
	10	2,127	3,048					1,236	296	2,371	1,431	3,506	2,567	4,642	3,702	5,777	4,837
	12	2,552	3,658							1,937	809	3,073	1,945	4,208	3,080	5,343	4,215
160	2	495	735	1,596	1,349	2,298	2,051	3,702	3,455	5,106	4,858	6,509	6,262	7,913	7,666	9,317	9,070
	4	989	1,469	1,087	593	1,789	1,294	3,192	2,698	4,596	4,102	6,000	5,506	7,404	6,909	8,807	8,313
	6	1,484	2,204			1,279	538	2,683	1,942	4,087	3,345	5,490	4,749	6,894	6,153	8,298	7,556
	8	1,978	2,938					2,174	1,185	3,577	2,589	4,981	3,992	6,385	5,396	7,789	6,800
	10	2,473	3,673					1,664	428	3,068	1,832	4,472	3,236	5,875	4,640	7,279	6,043
	12	2,967	4,407							2,558	1,076	3,962	2,479	5,366	3,883	6,770	5,287
190	2	940	1,185	2,694	2,441	3,914	3,662	6,355	6,103	8,797	8,545	11,238	10,986	13,679	13,427	16,121	15,868
	4	1,880	2,370	1,725	1,221	2,946	2,441	5,387	4,883	7,828	7,324	10,270	9,765	12,711	12,207	15,152	14,648
	6	2,821	3,555			1,977	1,221	4,419	3,662	6,860	6,103	9,301	8,545	11,743	10,986	14,184	13,427
	8	3,761	4,740					3,450	2,442	5,892	4,883	8,333	7,324	10,774	9,765	13,215	12,207
	10	4,701	5,925					2,482	1,221	4,923	3,662	7,364	6,104	9,806	8,545	12,247	10,986
	12	5,641	7,110							3,955	2,442	6,396	4,883	8,837	7,324	11,279	9,766
210	2	1,011	1,422	3,353	2,929	4,818	4,394	7,747	7,324	10,677	10,253	13,606	13,182	16,535	16,112	19,465	19,041
	4	2,021	2,844	2,312	1,465	3,777	2,929	6,706	5,859	9,636	8,788	12,565	11,718	15,494	14,647	18,424	17,577
	6	3,032	4,266			2,736	1,465	5,665	4,394	8,595	7,324	11,524	10,253	14,453	13,182	17,383	16,112
	8	4,043	5,688					4,624	2,930	7,554	5,859	10,483	8,788	13,412	11,718	16,342	14,647
	10	5,053	7,110					3,583	1,465	6,513	4,394	9,442	7,324	12,371	10,253	15,301	13,182
	12	6,064	8,532							5,472	2,930	8,401	5,859	11,330	8,788	14,260	11,718
253	1	742	1,021	5,578	5,299	7,684	7,406	11,898	11,619	16,111	15,833	20,324	20,046	24,538	24,259	28,751	28,473
	2	1,485	2,041	4,835	4,279	6,942	6,385	11,155	10,599	15,369	14,812	19,582	19,025	23,795	23,239	28,009	27,452
	3	2,227	3,062	4,093	3,258	6,200	5,365	10,413	9,578	14,626	13,792	18,840	18,005	23,053	22,218	27,266	26,432
	4	2,969	4,082	3,351	2,238	5,457	4,344	9,671	8,558	13,884	12,771	18,097	16,984	22,311	21,198	26,524	25,411
	5	3,712	5,103	2,608	1,217	4,715	3,324	8,928	7,537	13,141	11,750	17,355	15,964	21,568	20,177	25,782	24,390
	6	4,454	6,124			3,972	2,303	8,186	6,516	12,399	10,730	16,613	14,943	20,826	19,156	25,039	23,370
	7	5,196	7,144			3,230	1,282	7,443	5,496	11,657	9,709	15,870	13,922	20,083	18,136	24,297	22,349
	8	5,939	8,165			2,488	262	6,701	4,475	10,914	8,689	15,128	12,902	19,341	17,115	23,554	21,329
	9	6,681	9,185					5,959	3,455	10,172	7,668	14,385	11,881	18,599	16,095	22,812	20,308
	10	7,424	10,206					5,216	2,434	9,430	6,647	13,643	10,861	17,856	15,074	22,070	19,287
	11	8,166	11,227							8,687	5,627	12,901	9,840	17,114	14,053	21,327	18,267
	12	8,908	12,247							7,945	4,606	12,158	8,819	16,372	13,033	20,585	17,246

Torque Output Data

Single-Acting Actuators *continued*

Model	Springs	Spring Torque (lbf.in)		Pneumatic Torque (lbf.in)													
				30 psi		40 psi		60 psi		80 psi		100 psi		120 psi		140 psi	
		0°	90°	0°	90°	0°	90°	0°	90°	0°	90°	0°	90°	0°	90°	0°	90°
254	2	2,108	2,844	6,252	5,494	9,060	8,302	14,675	13,917	20,291	19,532	25,906	25,148	31,522	30,763	37,137	36,379
	4	4,215	5,688	4,082	2,564	6,889	5,372	12,505	10,988	18,120	16,603	23,736	22,218	29,351	27,834	34,966	33,449
	6	6,323	8,532			4,718	2,443	10,334	8,058	15,949	13,674	21,565	19,289	27,180	24,905	32,796	30,520
	8	8,430	11,376					8,163	5,129	13,779	10,744	19,394	16,360	25,009	21,975	30,625	27,591
	10	10,538	14,220					5,992	2,200	11,608	7,815	17,223	13,430	22,839	19,046	28,454	24,661
	12	12,645	17,064							9,437	4,886	15,052	10,501	20,668	16,116	26,283	21,732
255	2	2,409	3,594	8,138	6,918	11,678	10,458	18,758	17,538	25,838	24,618	32,918	31,698	39,998	38,778	47,078	45,858
	4	4,818	7,188	5,657	3,216	9,197	6,756	16,277	13,836	23,357	20,916	30,437	27,996	37,517	35,076	44,597	42,156
	6	7,228	10,783			6,715	3,054	13,795	10,134	20,875	17,214	27,955	24,294	35,035	31,374	42,115	38,454
	8	9,637	14,377					11,314	6,432	18,394	13,512	25,474	20,592	32,554	27,672	39,634	34,751
	10	12,046	17,971					8,832	2,730	15,912	9,810	22,992	16,890	30,072	23,969	37,152	31,049
	12	14,455	21,565							13,431	6,108	20,511	13,187	27,591	20,267	34,671	27,347
300	1	1,205	1,797	13,440	13,440	18,321	17,729	28,084	27,492	37,847	37,255	47,610	47,018	57,373	56,781	67,136	66,544
	2	2,409	3,594	12,235	11,050	17,117	15,932	26,880	25,695	36,643	35,457	46,406	45,220	56,169	54,983	65,932	64,746
	3	3,614	5,392	11,030	9,253	15,912	14,134	25,675	23,897	35,438	33,660	45,201	43,423	54,964	53,186	64,727	62,949
	4	4,819	7,189	9,826	7,456	14,707	12,337	24,470	22,100	34,233	31,863	43,996	41,626	53,759	51,389	63,522	61,152
	5	6,023	8,986	8,621	5,658	13,503	10,540	23,266	20,303	33,029	30,066	42,792	39,829	52,555	49,592	62,318	59,355
	6	7,228	10,783	7,416	3,861	12,298	8,743	22,061	18,506	31,824	28,269	41,587	38,032	51,350	47,795	61,113	57,558
	7	8,433	12,580	6,212	2,064	11,093	6,946	20,856	16,709	30,619	26,472	40,382	36,235	50,145	45,998	59,908	55,760
	8	9,637	14,377			9,889	5,148	19,652	14,911	29,415	24,674	39,178	34,437	48,941	44,200	58,704	53,963
	9	10,842	16,175			8,684	3,351	18,447	13,114	28,210	22,877	37,973	32,640	47,736	42,403	57,499	52,166
	10	12,047	17,972			7,479	1,554	17,242	11,317	27,005	21,080	36,768	30,843	46,531	40,606	56,294	50,369
	11	13,251	19,769					16,038	9,520	25,801	19,283	35,564	29,046	45,327	38,809	55,090	48,572
	12	14,456	21,566					14,833	7,723	24,596	17,486	34,359	27,249	44,122	37,012	53,885	46,775
	13	15,660	23,363					13,628	5,925	23,391	15,688	33,154	25,451	42,917	35,214	52,680	44,977
302	10	10,046	17,082	17,962	10,926	27,298	20,261	45,969	38,933	64,641	57,605	83,313	76,277	101,985	94,948	120,656	113,620
	11	11,055	18,790	16,953	9,217	26,289	18,553	44,960	37,225	63,632	55,897	82,304	74,568	100,976	93,240	119,647	111,912
	12	12,055	20,498	15,953	7,509	25,289	16,845	43,960	35,517	62,632	54,188	81,304	72,860	99,975	91,532	118,647	110,204
	13	13,064	22,206			24,280	15,137	42,951	33,809	61,623	52,480	80,295	71,152	98,966	89,824	117,638	108,495
	14	14,064	23,915			23,280	13,429	41,951	32,100	60,623	50,772	79,295	69,444	97,966	88,115	116,638	106,787
	15	15,073	25,623			22,271	11,720	40,942	30,392	59,614	49,064	78,286	67,736	96,957	86,407	115,629	105,079
	16	16,073	27,331			21,270	10,012	39,942	28,684	58,614	47,356	77,285	66,027	95,957	84,699	114,629	103,371
	17	17,082	29,039			20,261	8,304	38,933	26,976	57,605	45,647	76,277	64,319	94,948	82,991	113,620	101,663
	18	18,082	30,747			19,261	6,596	37,933	25,268	56,605	43,939	75,276	62,611	93,948	81,283	112,620	99,954
	19	19,091	32,456					36,924	23,559	55,596	42,231	74,267	60,903	92,939	79,574	111,611	98,246
	20	20,091	34,164					35,924	21,851	54,596	40,523	73,267	59,195	91,939	77,866	110,611	96,538
	21	21,100	35,872					34,915	20,143	53,587	38,815	72,258	57,486	90,930	76,158	109,602	94,830
	22	22,100	37,580					33,915	18,435	52,586	37,106	71,258	55,778	89,930	74,450	108,602	93,122
	23	23,109	39,288					32,906	16,727	51,577	35,398	70,249	54,070	88,921	72,742	107,593	91,413
	24	24,109	40,997					31,906	15,018	50,577	33,690	69,249	52,362	87,921	71,034	106,592	89,705
	25	25,118	42,705					30,897	13,310	49,568	31,982	68,240	50,654	86,912	69,325	105,583	87,997
	26	26,119	44,413					29,897	11,602	48,568	30,274	67,240	48,945	85,912	67,617	104,583	86,289
	27	27,127	46,121							47,559	28,566	66,231	47,237	84,903	65,909	103,574	84,581
	28	28,128	47,829							46,559	26,857	65,231	45,529	83,902	64,201	102,574	82,872
	29	29,137	49,538							45,550	25,149	64,222	43,821	82,893	62,493	101,565	81,164
30	30,137	51,246							44,550	23,441	63,222	42,113	81,893	60,784	100,565	79,456	
31	31,146	52,954							43,541	21,733	62,213	40,404	80,884	59,076	99,556	77,748	
32	32,146	54,662							42,541	20,025	61,213	38,696	79,884	57,368	98,556	76,040	

Dimension Data and Mounting Standards

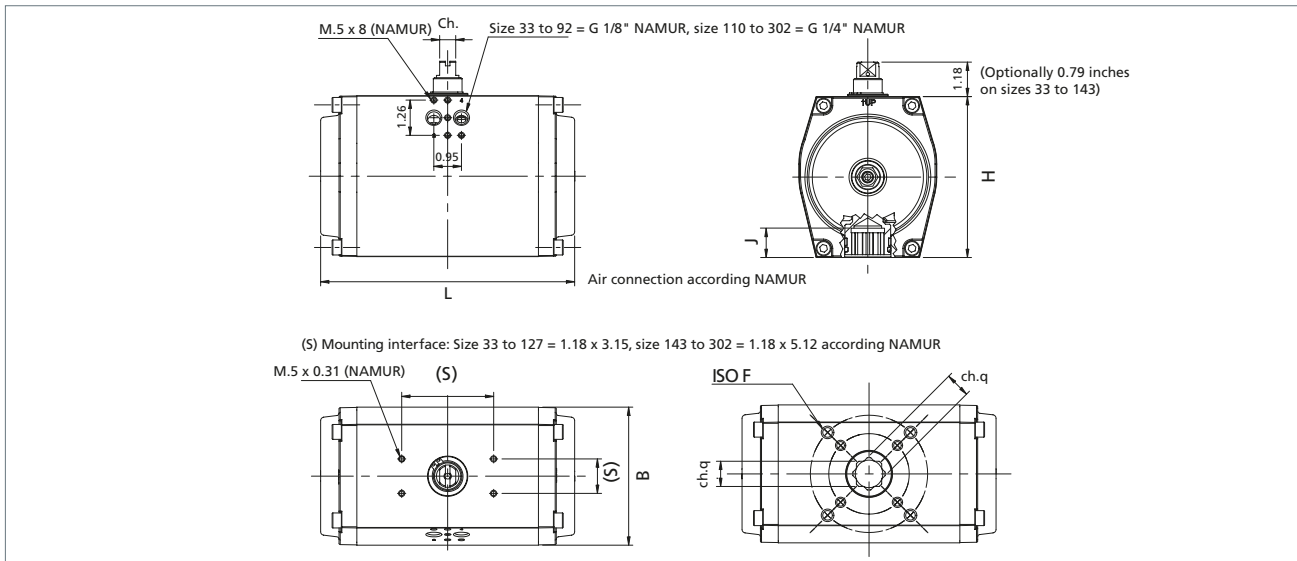

Model	Dimensions (inch)									Displacement (Cubic inches)				Weight (lbs)			
	L			H	J	B	Ch	Ch.q	ISO	SR 90°	DA			SR 90°	DA		
	90°	120°	180°								90°	120°	180°		90°	120°	180°
33	3.54	-	-	2.56	0.512	2.42	0.394	0.354	F03	-	9.15	-	-	-	1.04	-	-
34	3.54	-	-	2.56	0.512	2.42	0.394	0.354	F04	-	9.15	-	-	-	1.04	-	-
43	4.57	-	-	2.56	0.512	2.42	0.394	0.354	F03/F05	6.10	11.0	-	-	1.46	1.32	-	-
44	4.57	-	-	2.56	0.512	2.42	0.394	0.354	F04	6.10	11.0	-	-	1.46	1.32	-	-
52	5.24	5.94	7.68	2.91	0.709	2.70	0.394	0.551	F03/F05	7.93	15.3	17.1	28.1	2.20	1.98	2.43	2.87
63	5.39	6.10	7.87	3.46	0.787	3.15	0.394	0.551	F05/F07	12.8	24.4	27.5	45.2	3.57	3.20	3.75	4.41
75	6.34	7.20	9.33	3.94	0.787	3.64	0.394	0.669	F05/F07	19.5	36.6	41.5	68.3	5.40	4.63	5.42	6.39
83	7.09	8.07	10.55	4.25	0.787	3.92	0.394	0.669	F05/F07	27.5	53.7	61.0	99.5	6.50	5.51	6.50	7.72
92	8.23	9.41	12.20	4.61	0.827	4.35	0.551	0.669	F05/F07	37.8	73.2	82.4	137	8.82	7.50	8.82	10.1
110	8.78	9.96	12.72	5.51	1.004	4.72	0.551	0.866	F07/F10	59.8	116	131	215	13.7	11.5	13.4	15.9
118	11.54	13.58	16.89	5.51	1.417	4.72	0.787	0.866	F07/F10	85.4	165	186	305	18.4	15.7	17.6	21.4
127	11.85	13.90	17.83	6.30	1.417	5.39	0.787	0.866	F07/F10	122	223	250	415	23.6	19.8	22.0	27.6
143	13.27	15.24	19.21	7.80	1.299	6.77	0.787	1.063	F10/F12	153	281	373	561	34.8	27.4	30.9	35.3
160	14.92	17.48	22.44	7.80	1.535	6.77	1.102	1.063	F10/F12	232	427	488	793	44.3	36.2	41.4	57.3
190	16.61	-	-	10.04	1.614	8.82	1.102	1.417	F12/F16	397	763	-	-	83.2	61.6	-	-
210	18.43	21.42	27.40	10.04	1.575	8.82	1.260	1.417	F10/F14	488	915	1,037	1,312	87.3	70.1	82.5	108
253	20.63	23.62	29.57	11.89	1.969	10.71	1.260	1.811	F16	610	1,172	1,343	1,770	123.46	97.00	110.23	138.89
254	23.98	27.99	35.87	11.89	1.969	10.71	1.260	1.811	F16	854	1,648	1,922	2,502	156	122	147	176
255	27.13	32.09	-	11.89	1.969	10.71	1.260	1.811	F16	1,037	1,953	2,319	-	186	153	170	-
300	27.12	32.04	-	14.17	1.969	14.17	1.26	1.811	F16	1,526	2,807	4,150	-	235.89	202.83	231.49	-
300-F25	27.12	32.04	-	15.43	2.559	14.17	1.26	2.16	F25	1,526	2,807	4,150	-	251.33	218.26	149.91	-
302	46.30	-	-	14.17	1.969	14.17	1.26	1.811	F16	2,807	5,126	-	-	394.63	317.47	-	-
302-F25	46.30	-	-	15.43	2.559	14.17	1.26	2.16	F25	2,807	5,126	-	-	394.63	339.51	-	-

SR = Spring-Return DA = Double-Acting

Optional Body Air Connections

- 1/2" NPT (sizes from 110 to 302)
- 3/4" NPT (sizes from 253 to 302)
- 1" NPT (sizes from 300 to 302)

Optional Bottom Flange Drilling

- ISO F04 (for sizes 52, 63, 75)
- ISO F05 (for size 110)
- ISO F07 (for size 143)
- ISO F10 and F12 (for size 190 and 210)
- ISO F12 (for size 127)
- ISO F14 (for size 253)
- ISO F12 and F16 (for size 254)
- ISO F25 (for sizes 300 and 302)

Optional Valve Shaft Interface

- Single square parallel ISO 5212
- Single square diagonal ISO 5213
- Double D

Note: standard is double square ISO 5211.

Model Number Designation

Example Model Number **GTA - 52 - FC - 04 - W - ST**

Range and Rotation

GTA = 90° rotation
GTB = 120° rotation
GTC = 180° rotation

Body Size

33, 34, 43, 44, 52, 63, 75, 83, 92, 110, 118, 127, 143, 160, 190, 210, 253, 254, 255, 300, 302

Effect

DA = Double-acting
FC = Spring-return, fail to close (clockwise)
FO = Spring-return, fail to open (counter-clockwise)

Spring Set

01, 02, 03, 04, 05, 06, 07, 08, 09, 10, 11, 12, 13, 14, 15, 16, 17, 18, 19, 20, 21, 22, 23, 24, 25, 26, 27, 28, 29, 30, 31, 32 (not applicable for double-acting)

Travel Stop

X0 = No end stop (33, 34, 43 and 44 body size only)
K0 = Single direction +/- 5 degrees
K1 = Single direction +5 to -90 degrees
W0 = Dual direction +/- 5 degrees open, +5 to -25 degrees close
W1 = Dual direction +5 to -90 degrees open, +5 to -25 degrees close
Z0 = Blocked end stop

Temperature Range

ST = Standard -58 to +158 °F (-50 to +70 °C)
HT = High +5 to +320 °F (-15 to +160 °C)
ET = Extended -76 to +392 °F (-60 to +200 °C)
SX = Special (consult factory)



Assembly Configurations

The graphics below show the relative orientation of the piston and pinion for each configuration, as viewed from the top side of the actuator. In the descriptions that follow, that perspective is assumed. Pinion rotation is indicated for each as CW (clockwise) or CCW (counter-clockwise).

Port 2 is connected to the inboard side of the pistons. Pressurising port 2 will force the pistons out until they reach the travel stops. The direction of pinion rotation is determined by the assembly configuration. Venting is through port 4.

Port 4 is connected to the outboard side of the pistons. Pressurising port 4 will force the pistons in until they reach the travel stops (if the actuator is so equipped as they're optional). The direction of pinion rotation is determined by the assembly configuration. Venting is through port 2.

Note that on spring-return actuators, as with double-acting, pressurising port 2 will move the pistons out. When port 2 is depressurised, spring force will move the pistons in. Venting is through port 4. Port 4 is not to be pressurised on spring-return actuators.

Consult the GT Range Installation and Commissioning Manual or Rotork for detailed connection and operation information.

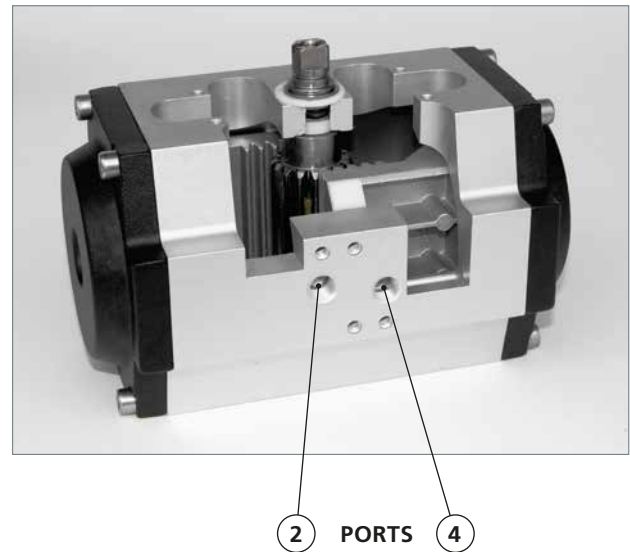

STYLE	PORT 4 (OUTBOARD) PRESSURISED <i>Shown at end of stroke</i>	PORT 2 (INBOARD) PRESSURISED <i>Shown at end of stroke</i>
A STANDARD	CW 	CCW
B OPTIONAL	CW 	CCW
C OPTIONAL	CCW 	CW
D OPTIONAL	CCW 	CW

rotork®



www.rotork.com

A full listing of our worldwide sales and service network is available on our website.

Rotork plc
Brassmill Lane, Bath, UK
tel +44 (0)1225 733200
email mail@rotork.com

PUB110-002-00
Issue 02/22

As part of a process of on-going product development, Rotork reserves the right to amend and change specifications without prior notice. Published data may be subject to change. For the very latest version release, visit our website at www.rotork.com

The name Rotork is a registered trademark. Rotork recognises all registered trademarks. Published and produced in the UK by Rotork. POLTG0222