

JACOBY-TARBOX®

100 years of Quality!



- Increase duty cycle
- Maximize process output
- Minimize down time
- Consistent performance

Compliance... “Out of the Box”



B2.1

Section VIII

B16.5

B31.1

B31.3



NACE®

ASME BPE

ASTM

BioProcessing Equipment



DIN

PED

CRN



JIS

MIL

Innovative solutions to extend your window's duty cycle...

Shielding: UniShield® Window Protection

UniShield is your **early warning device**, showing changes in shield **BEFORE** glass integrity is compromised.

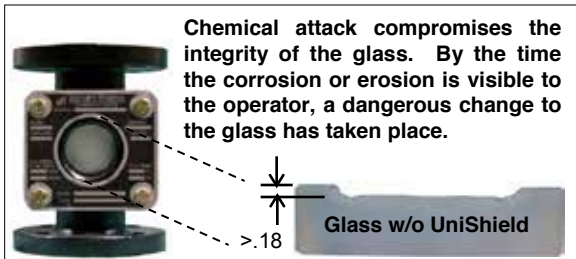

Vacuum Rated
Shielding
UniShield®

Only from
Jacoby-Tarbox

SEE Without Darkening



UniShield

Mica

Glass Safety: UniGlas® Safety Sight Window Glass

30 years without a break!

- **Highest safety factor at 10:1** → Safe and Dependable
- **Greatest impact resistance** → Tough, Pre-stressed Glass
- **Reusable** → ONLY *glass fused to metal optical discs* may be placed back into service safely after use
- **Simple maintenance** → **One piece** – No glass bonding agents, shims, packing, or adjustment screws



Lighting: Phaeton® XTL & SL Explosion Proof Lights

Explosion Proof power supply and Intrinsically Safe output

- **Save money in design with Single window Viewing**
Second, light-only window not required for 4" (DN 100) and larger
- **Easy Installation to RETROFIT nearly ANY UNIT**
No disassembly or modification of the existing equipment
- **Safe "no burn" LED light source**
Will not "bake on" glass
- **Decreases maintenance costs**
Uses vibration-resistant 100,000-hour LED's



Phaeton XTL



Sight Flow Indicators

Full ASME - ONLY ASME B31.1 and B31.3 Metals in Construction

**Horizontal
Upward Vertical Flow**

FLAPPER



Medium Pressure
- Class 150 910-FA

High Pressure
Class 300 / 600 F-910HPA -300 / 600
Class 900 / 1500 F-910HPA -900 / 1500

Any Flow Direction

ROTOR



935-FA

F-960HPA -300 / 600
F-960HPA -900 / 1500

**Downward Vertical Flow
"less than full" horizontal lines**

DRIP



608-FA

F-608HPA -300 / 600
F-608HPA -900 / 1500

FLAPPER



Nominally Rated
- 150 psig (10.3 Bar) 100-ST

Full ASME
- Class 150 100-SA
- CL300 / CL600 S-100HPA-CL3 / -CL6
- CL900 / CL1500 S-100HPA-CL9 / -CL15

ROTOR

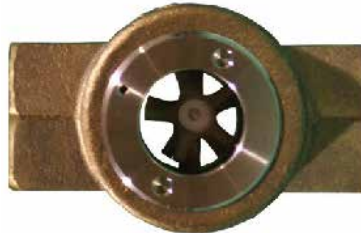

300-ST

300-SA
S-300HPA-CL3 / -CL6
S-300HPA-CL9 / -CL15

DRIP



200-ST

200-SA
S-200HPA-CL3 / -CL6
S-200HPA-CL9 / -CL15

Plain or "No Flap"

Add "(NF)" to any Flapper model
Any Flow Direction

PLAIN



910-FA (NF)
shown

**Highest Pressure Ratings
- Up to CL1500
(3750 psig / 259 bar)
Flanged, Threaded, Socket
Weld, Butt Weld, and other
connections**

Gas Indicator

Add "GI" to any Flapper model
Ultra-Low Volume Gas Flow

FLAPPER
GAS INDICATOR



100-ST-GI
shown

Specialty Units

NEW 90-LR

- **Save space and Save weight** (combine elbow and indicator)
- CL150 & CL300 systems
- Plain or with a drip tube
- Flow in any direction (plain unit)



Side Connections

- **Connect instruments** thermometers, thermo wells and flow switches
- **Sample or drain system**
- **Add secondary process**
- **Maintain system integrity** NO change in unit rating
- Connections female NPT coupling, Male NPT, and flanged



Jacketed

- **Improved temperature control**
- Jacketed processing lines
- Clamp-on (standard)
- Weld-on (available)



Tubular

- **Maximum visibility**, "any angle" viewing
- Pressure rating: 150 psig (10.3 Bar) or less, changes with size
- Special lengths: up to 48" (1219 mm) in length for flange sizes from 1/2" to 12"
- Must isolate from mechanical strains on pipelines



805-S Threaded connection



830-F Flanged connection

Sheathed Tubular

- **Rugged environments with minimal ambient light**
- Increased visibility with cylinder protection from rigid, non-wetted body
- Pressure ratings are 150 psig (10.3 Bar) or less (varies by size)
- Stuffing box seal eliminates direct end loading of glass



4000-S Threaded Connection



860-F Flanged connection

Hygienic Units

Hygienic models designed in accordance with ASME-BPE are imperative for biotechnology, pharmaceutical, cosmetic, and food & beverage processing systems.

Hy-Sight™

- **Superior Cleanability** – Precision bore glass, controlled O-ring compression
- **Smooth transition**, exceeding CIP & SIP requirements
- **Maximum visibility**
- **Simple maintenance** with "No Gall" ACME threads



TRU-SAN®

- Bulls-eye style with UniSan windows
- **Easy installation**, body will match system design Hygienic Clamp or butt weld ends

UNI-SAN®

- **Protect process** from contamination while viewing
- **No breakage** concern
- **Impact resistant** glass fused to metal construction



Severe Service Solutions

UniGlas® & Other Glass Materials

SINGLE WINDOW

(one per side, two per unit)

Borosilicate glass

- Jacoby-Tarbox® standard, used to 500°F (260C)

UniGlas (more on page 3)

- **Greatest Temperature Range** offered by any manufacturer for glass fused to metal disc
- Suitable for **Cryogenic service**

Quartz

- **Thermal shock resistant**
- Elevated temperatures to 2000 F (1100C)
- Chemical shielding

Single Window
(UniGlas® shown)

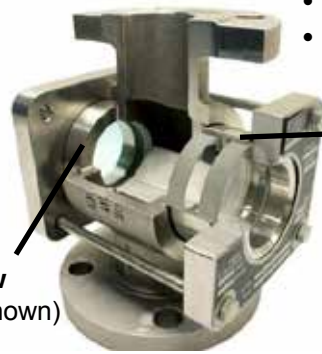

IMPORTANT!
****UNIT RATING MAINTAINED****
FOR ALL WINDOW MATERIALS.
(UniGlas®, Quartz, and all Dual Window)

DUAL WINDOW OPTION

(two per side, four per unit)

- FM Approved window assembly
- Two identical windows = 100% redundancy
- Independently mounted at each opening
- Available in Borosilicate, UniGlas®, Quartz



Dual Window

(Borosilicate shown)

Dual Window Applications

- Thermal shock
- Extreme process changes
- Rough environments (external impact)

Body (head) Materials

- Standard materials: Carbon Steel, 316 stainless steel, Bronze
- Match specific performance requirements with common specialty alloys: Alloy 20, Duplex, Hastelloy®, Inconel®, Monel®, other stainless steels and other special alloys

Gasket Materials

- Standard material: Neoprene
- Match specific performance requirements for chemical resistance or elevated temperatures: PTFE Gylon® 3545, Fiber (IFG 5500), Graphite, FKM, other special materials

Linings

– Fluoropolymer lined sight flow indicators and More

- **Corrosion-resistant linings:** fluoropolymers such as PFA, Edathon, ETFE, and more
- **Cost savings** over indicators manufactured from high performance body materials
- **Match any service requirements**
Internal protection only (lining)
Internal and external protection (encapsulating)
Full vacuum service
High pressure service



910-FA-PFA
Carbon steel encapsulated in PFA

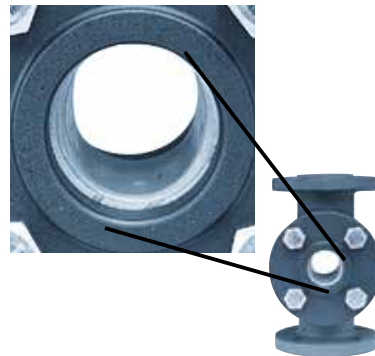

910-FA-TEFLON®
Isostatically Molded Teflon® Liner



830-F-TFE
Tubular unit with replaceable PTFE liner
(Shown with optional external impact shield)

Sight Windows

- Economical tank viewing
- Meet all connection requirements
- Light duty to severe service
- Customize to your requirements

Security Sight Window

- Model 5005-DW: Patented **Factory Mutual® Approved** Dual Window standard
- **Protection** against stress concentration, thermal shock, corrosion, erosion, overpressure
- Corrosion resistant linings: PTFE, PFA, and rubber
- Bolt-on to ASME standard flanges
- Pressure range: Full Vacuum (FV) to 1500 psig (103 bar)



5005-DW

Bolt-On

- **Model 5800 UniGlas Sight Window**
- Simple, two-piece, ASME rated units, UniGlas® window plus retaining flange
- Strongest, safest, most impact resistant
- Bolt-on to ASME standard flanges
- Pressure range: FV to 1500 psig (103 bar)



5800

Pressure Vessel Weld-On

- Section VIII of the ASME Boiler & Pressure Vessel Code
- "PVQ" = Pressure Vessel Quality
- Window options - UniGlas® (round only), Dual Window tempered, UniGlas, or Quartz
- Flat weld pad standard
Curved pads available with cylindrical and spherical radius cuts
- Pressure range: FV to 600 psig (41.3 bar)



5200-PVQ

5300-PVQ
Obround

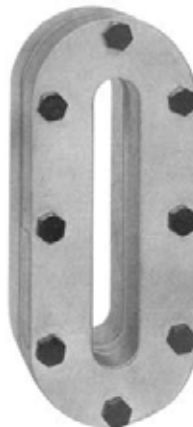

Weld-On

Weld Neck Sight Windows - welded directly to pipe ends or into tank and vessel walls

W-5000



Weld Pad Sight Windows

- Non-ASME vessels
- Welded directly to tank or vessel walls or covers
- Flat, cylindrical or spherically shaped pads
- Pressure range: FV to 150 psig (10.3 bar)

Threaded

- Threading directly to pipe ends or couplings
- Pressure range: FV to 150 psig (10.3 bar)
- Specialty UniGlas sight plugs available for higher pressures



S-5400
Male Thread



S-5100
Female Thread



5200 Commercial

Eductors

- Safely pump hazardous fluids → move liquids via vacuum
- Maximize service life → special chemical and wear resistant alloys
- Shortest blending times → Greatest entrainment ratio
- Scale up with confidence → simulate processes prior to construction

Designed to ASME B31.1 & B31.3 Requirements

In-line Eductors

- **Decrease maintenance cost** – No moving parts
- **Use less energy** – Venturi-based pumping of liquids, gases, and even solids
- Also known as Jet Pump, Injector, Ejector, Jet Syphon, Steam Syphon, Venturi Pump,



In-Tank Eductors

- **Use less energy** – More efficient than nozzles alone, to Mix, blend, suspend solids and heat
- **Decrease maintenance cost** – No moving parts
- **Smaller pump required** – Amplifies pump capabilities
- **Heat more quietly and efficiently** than sparging



TLA – Tank Liquid Agitator

Connection Offerings Your Application Requires

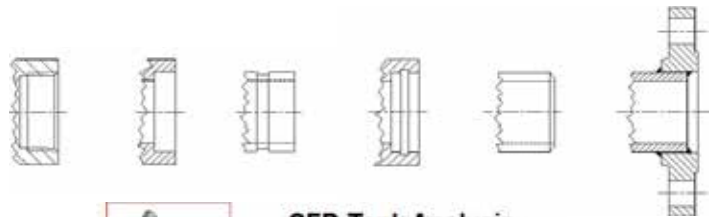

CFD Analysis Available

- Verify your process with Analysis of current mixing
- Optimize mixing performance
- Increase productivity

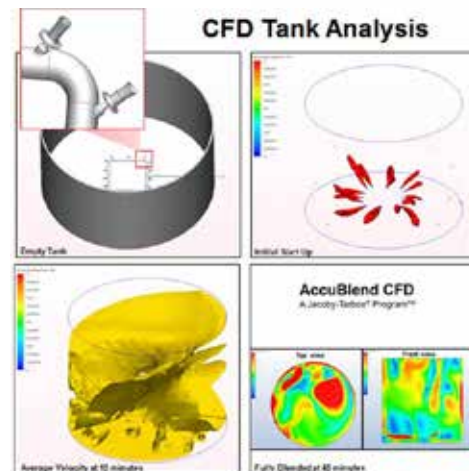

16633 Foltz Parkway • Strongsville, OH 44149 USA
 Telephone: +1 440- 572-1500 • Fax: +1 440-238-8828

jacoby-tarbox.com • jacobytarbox@clark-reliance.com • clark-reliance.com/parts