

PNEUMATIC ACTUATORS

Installation & Maintenance Instructions

(Including Parts List) MI 0998

P.O. Box 275 • North Kingstown, RI 02852 • Phone: 401-294-1400 • Fax: 401-294-3388
E-Mail: sales@rciactuators.com • Website: www.rciactuators.com

INTRODUCTION

RC Compact Pneumatic Actuators are intended for on-off and proportional control on quarter-turn valves. The design features a modern Scotch Yoke. This instruction covers the following actuators:

RC 210, 230, 250, and 270 (one piston)

RC 220, 240, 260, and 280 (two pistons)

Type DA (Double Acting)

Type SR Single Acting-Spring Return

Type SR actuators can be arranged for valves to "Fail Close" (CW rotation) or "Fail Open" (CCW rotation)

DOUBLE ACTING (DA) ACTUATOR

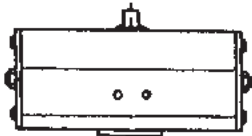

For clockwise to close valves, pressure to the left port closes the valve, pressure to the right port opens the valve.

SPRING RETURN (SR) ACTUATOR



For clockwise to close valves, pressure to the left port opens the valve. The right port is an exhaust port from the spring chamber(s).

STANDARD SPECIFICATIONS

Ambient Temperature Limits: -4 to +175°F

Operating Medium: Filtered dry air or inert gas

Maximum Working Pressure: 150 PSI

Pneumatic piping to the actuator and associated accessories should follow the best practices for instrument pneumatic piping systems, i.e.: lines free of all water, oil or other contaminants, etc.

The operating medium is to be filtered dry air or inert gas which is filtered to 30 micron particle size or less. It is extremely important that the actuator be powered with an adequate air supply. Inadequate air could cause the valve to fail to operate.

The Spring housings on SR actuators, if not piped, will breath through the right hand port, see sketch (above). It's important that it not be exposed to a corrosive atmosphere. Please contact Remote Control for possible solutions if this condition exists.

INSTALLATION OF ACTUATOR

RC actuators are adapted to the valve by means of an intermediate bracket and coupler. The coupler adapts the ISO or DIN/ISO female output of the actuator to the valve shaft.

Standard mounting kits provide for mounting the actuator body in the direction of the pipe. Pipelines can be horizontal, vertical, or other positions. When mounting on a valve, the axis of the actuator drive shaft and valve shaft must be in line. Intermediate couplings must allow for axial clearance of .020" to .040", depending on actuator size, between valve shaft and bottom of drive socket. This axial clearance must be added to any valve stem rise which may be applicable. After mounting, it may be necessary to adjust the end of travel limit stop (yoke turning angle).

LUBRICATION

RC actuators are permanently lubricated and additional lubrication is not normally required. However, for actuators performing 100,000 cycles or more under a very heavy load, an oil mist lubrication is recommended. Oil mist lubrication requires a mineral oil type ISO VG32 class 1 for useage in temperature range 15 to 158°F. Oil mist lubricator must be set at the lowest possible value. Once begun, the oil mist lubrication cannot be discontinued.

CAUTION: If the actuator is equipped with a pneumatic or electro pneumatic positioner or pneumatic controller, oil mist lubricated air cannot be used unless the instrument manufacturer indicates that the instrument is compatible with lubricated air.

RECOMMENDED LUBRICATION GREASE

Cylinder bore and drive shaft with shaft seals and bearings	Grease
RC 200 standard and high temp	Cargo White Grease Klüber Isoflex Topas NCA 52
RC 200 low temp	Klüber Isoflex Topas NCA 52
Piston Roller (21)	Grease
All RC 200	Cargo Red Grease Klüber Unimoly GL 82

ORIENTATION OF PISTONS

Type DA

The pistons of standard Type DA Actuators are mounted as shown in figure 1. This provides for the highest torque at the "closed" (CW) valve position for valves that rotate clockwise to close. The pistons are then in their outermost position and the end of travel stop (yoke turning angle) can be fine adjusted $\pm 3^\circ$. To enable this adjustment to be done in the "open" (CCW) valve position, turn the pistons 180° about their axis as shown in Figure 3.

Type SR

The pistons of standard Type SR Actuators are mounted as shown in Figure 3. Although spring force is diminished, the geometry of the mechanism provides a greater torque at the end of the spring stroke than at mid stroke. When the actuator is in the "Open" valve position (Springs fully compressed), the end of travel stop, (turning angle), can be fine adjusted $\pm 3^\circ$.

Changing from "SPRING CLOSES" to "SPRING OPENS" (or Vice Versa)

CAUTION!! - STORED ENERGY - This procedure MUST be followed for safe removal of pretensioned spring housings. Serious injury or damage could result from failure to follow these instructions.

Refer to Figures 2 & 3

1. Shut off pneumatic (or hydraulic) supply and vent actuator.
2. Remove actuator from valve.
3. Disconnect any electrical power.

4. Confirm that the springs are fully extended as shown in figure 3. This can be confirmed by observing that the flats on the top drive shaft are 90° to the actuator axis on a "Fail Close" (fails CW) when viewed from the top of the actuator and parallel to the axis on a "Fail Open" (fails CCW) when viewed from the top of the actuator.
 5. Loosen Locknut (29).
 6. Rotate tensioning screw (26) counterclockwise until resistance is felt, then turn one more full turn.
 7. Remove screws (4).
 8. Remove spring pack(s) from actuator.
 9. Rotate drive shaft (15) until the pistons are at the end of the cylinder. This can be done by turning the drive shaft with a wrench on the flats or by clamping the shaft between soft jaws in a vise and turning the actuator. Insert two close fitting rods in the holes on the end of the piston and, squeezing them, pull the piston(s) from the cylinder.
 10. Rotate drive shaft 90°.
 11. Grease cylinder surface (see table above)
 12. Rotate piston(s) 180° about their axis and reinstall them as shown in figure 1.
 13. Ensure that pistons are lined up so that roller bearing (21) engages scotch yoke correctly. Once pistons are in, rotate shaft 90° to draw pistons in and confirm proper engagement. Pistons should now be in their innermost position. On sizes RC 230 through RC 280, align spring assembly so that one of three support points falls between the bosses on the piston and pins engage holes in the piston.
 14. Install screws (4).
 15. Rotate tensioning screw clockwise until resistance abates and turn one more full turn.
 16. Tighten locknut (29).
- The adjustment will then take place at the air end position.

ADJUSTMENT OF THE TURNING ANGLE

The $\pm 3^\circ$ adjustment of the end of travel stop described in the section on Orientation of Pistons is accomplished by loosening the lock nut on the end plate and turning the adjusting screw clockwise for reduced and counterclockwise for increased rotary motion. RC 220, 240, 260, and 280 actuators have two adjustment screws. It is important that both screws are in contact with their respective pistons.

MANUAL OPERATION

All actuators have a drive shaft with two flats for manual operation. However, because of the potential for stored energy in the actuator and the possibility of injury, it is strongly recommended that actuators size RC 230 and larger be equipped with M1 Manual Handwheel Override for manual operation.

CAUTION: Actuators must be vented before attempting manual operation.

MAINTENANCE

CAUTION: Before removing any components of the actuator, ensure that all pneumatic (or hydraulic) and electrical power supplies are disconnected.

Replacement of Shaft O-Rings

The shaft O-rings (18) & (38) and the support washers (33) & (39) can easily be replaced. Refer to figure 2.

1. Vent actuator.
2. Remove circlip locking rings (31) & (40).
3. Replace O-rings and support rings.

Note: Use a high quality grease when installing new parts. (See table on page 1.)

4. Replace circlip locking rings. The rounded inner edge is to be toward the center of the actuator. Do not spread more than necessary to get it over the shaft. It should fit tightly in the groove with no play.

REPLACEMENT OF O-RING AND SUPPORT BAND FOR DA ACTUATORS

Replacement of the piston O-ring is required if the O-ring is not holding air pressure.

1. Vent actuator.
2. Remove end plate(s) (5).
3. Rotate drive shaft (15) until the pistons are at the end of the cylinder. This can be done by turning the drive shaft with a wrench on the flats or by clamping the shaft between soft jaws in a vise and turning the actuator. Insert two close fitting rods in the holes on the end of the piston and, squeezing them, pull the piston(s) from the cylinder.
4. Replace O-ring (12).
5. Replace wear band (14).
6. Replace the support element (9). It should "pop" off with minimal effort.
7. Grease cylinder surface before reassembling. See table on page 1.
8. Install piston. Ensure that pistons are lined up so that roller bearing (21) engages scotch yoke correctly. Once pistons are in place, turn the drive shaft to draw pistons in and confirm proper engagement.
9. Mount end plates.
10. Replace O-ring (3) under lock nut (2).
11. Turn drive shaft to extend pistons and fine adjust end of travel stop (1).
12. Tighten lock nut (2)

NOTE: For two piston actuators (RC 220DA, RC 240DA, RC 260DA, RC 280DA), it is important that both travel stops contact pistons equally.

REPLACEMENT OF O-RING AND SUPPORT BAND FOR SR ACTUATORS

Refer to figures 2 & 3

1. Loosen lock nut (29).
2. Rotate tensioning screw (26) counterclockwise until you feel resistance and turn one more full turn.
3. Remove screws (4).
4. Remove spring pack from actuator.
5. Follow steps 3 through 8 for DA actuators.

Assembling

6. Replace O-Ring on spring cartridge(s) and end plate, if applicable.
7. Mount spring assembly with pistons in their innermost position. On sizes RC 230 through RC 280, turn spring assembly so that one of three support points lies between bosses on piston and pins engage holes in piston.
8. Install screws (4).
9. Rotate tensioning screw clockwise until resistance abates, and turn one more full turn.
10. Tighten locknut (29).

CHANGING DA TO SR ACTUATORS

All DA actuators can be changed to SR actuators by adding spring conversion kits as follows:

1. Pretension spring assembly using item (26). Refer to Table 1 and Figure 4.
2. Vent actuator.
3. Remove end plates.
4. Follow instructions above for removing piston(s) (10).
5. Rotate shaft 90°.
6. Grease cylinder surface see table on page 1.
7. Turn pistons 180° about their axis and reinstall them per figure 3.
8. Follow instructions above for reinstalling pistons.

Note: Refer to instruction on assembling SR actuators above for installation of spring packs.

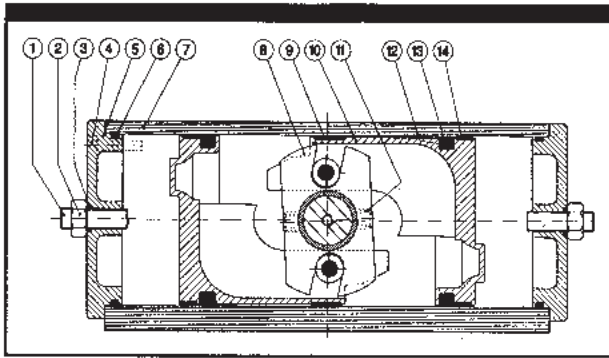

Figure 1 - RC 200-DA from above

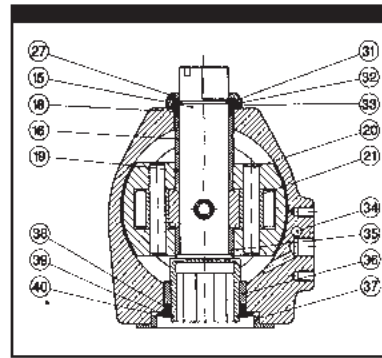

Figure 2 - Top Side

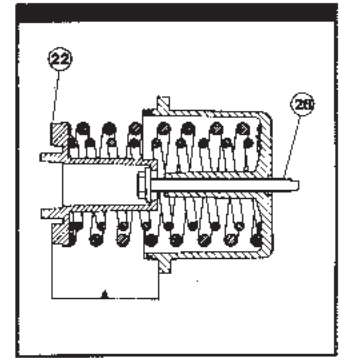

Figure 4 - Spring Pack Pretensioning

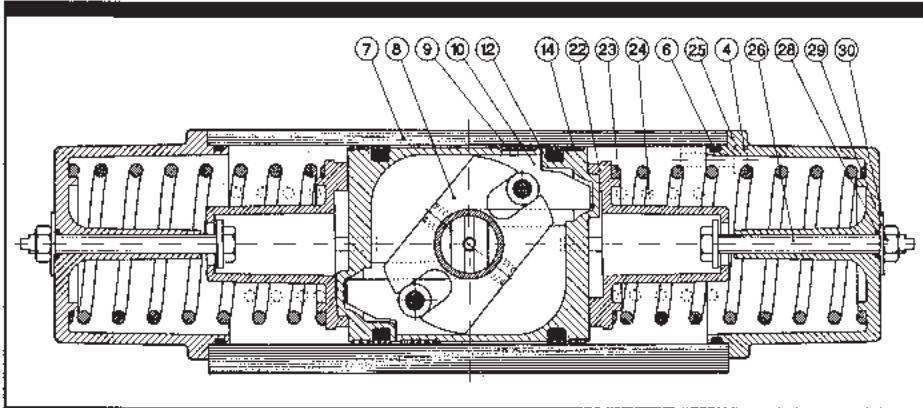

Figure 3 - RC 200-SR from above

Actuator	Dimension "A" inches (mm)
210-220	1.61 (41)
230-240	2.44 (62)
250-260	3.43 (87)
270-280	5.39 (137)

Table 1 - Pretensioning Dimension "A"

INSTRUCTIONS FOR DISMANTLING OF RC 200-SR ACTUATORS WITH MANUAL OPERATION UNIT TYPE M1

CAUTION

Do not remove the protective tube (50) and handwheel from the spring housing as long as the springs are under tension. This procedure must be followed for safe removal of pretensioned spring housings.

DISASSEMBLY MUST BE PERFORMED EXACTLY AS FOLLOWS. SERIOUS INJURY OR DAMAGE COULD RESULT FROM FAILURE TO FOLLOW THESE INSTRUCTIONS. CONTACT REMOTE CONTROL IF AT ALL UNCERTAIN.

1. Shut off pneumatic (or hydraulic) supply and vent actuator.
2. Confirm that the springs are fully extended as shown in figure 5. This can be confirmed by observing that the flats on the top drive shaft are 90° to the actuator axis on a "Fail Close" (fails CW) when viewed from the top of the actuator and parallel to the axis on a "Fail Open" (fails CCW) when viewed from the top of the actuator.
3. Turn the handwheel so that the threaded stem (51) moves toward the actuator until it stops and the stem can just barely be seen in the plastic tube (49).
4. For sizes RC 220, 240, 260 and 280 (i.e. actuators with two pistons): adjust the tensioning screw (26) in the opposite spring housing counter clockwise until it contacts the spring guide (22). Remove the spring housing by removing the screws (4).
5. Turn the handwheel until there is resistance and the threaded stem (51) can be seen slightly to the right of neutral position "N" (see figure 5).
6. Remove the spring housing of the manual override by removing the retaining screws (4) and turn the handwheel several turns in the direction which gives the least resistance.

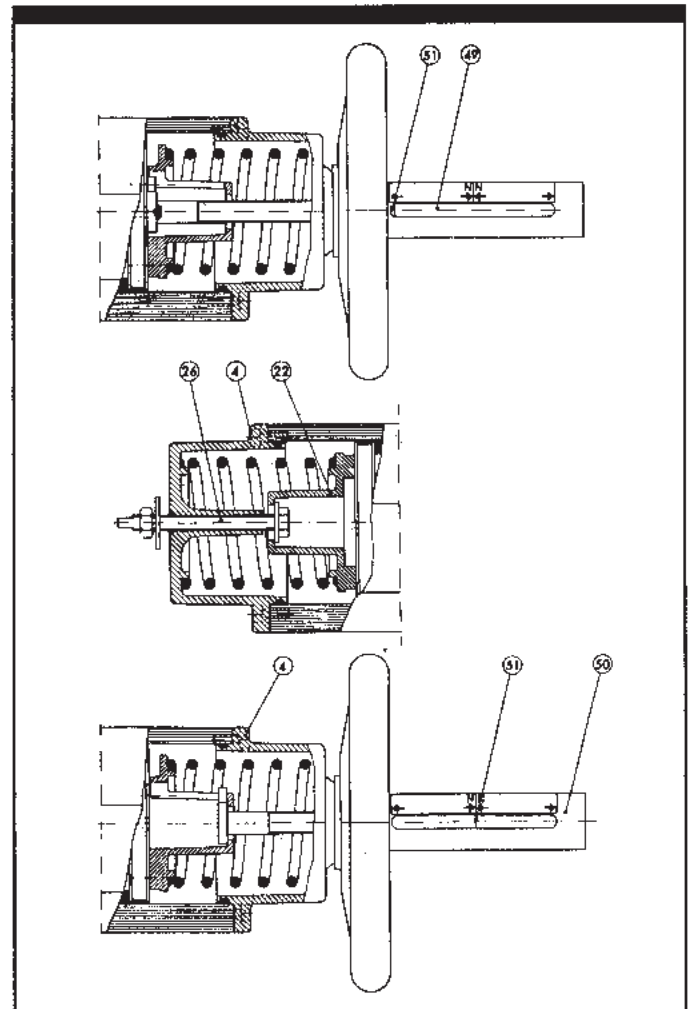

Figure 5

MATERIAL TABLE FOR RC 210-280

Item Number	Description	Quantity RC 200DA	Quantity RC 200-SR	Material	Surface Treatment
1	Adjusting screw ¹	1	--	Sizes 210-260: Stainless steel 270, 280: Steel	Zinc plated
2	Lock nut ¹	1	--	Sizes 210-260: Stainless steel 270, 280: Steel	Zinc plated
3*	O-ring ¹	1	--	Nitrile	
4	Screw	8-16	8-16	Sizes 210-260: Stainless steel 270, 280: Steel	Zinc plated
5	End plate with center hole ¹	1	--	Aluminum	Anodized
6*	O-ring	2	2	Nitrile	
7	Cylinder	1	1	Aluminum	Anodized
8	Scotch yoke	1	1	Steel	
9*	Support element ¹	1	1	POM/PTFE	
10	Piston ¹	1	1	Aluminum	
11	Roll pin, double ^{2,3}	1	1	Spring steel	
12*	O-ring ¹	1	1	Nitrile	
14*	Support band ¹	1	1	PTFE filled	
15	Drive shaft	1	1	Sizes 210-260: Stainless steel 270, 280: Steel	Yellow chromated
16	Bearing, upper	1	1	Polymer material	
17	End plate without center hole ⁴	1	1	Aluminium	Anodized
18*	O-ring, upper	1	1	Nitrile	
19	Support ring, upper	1	1	Polymer material	
20	Piston pin ¹	1	1	Steel	
21	Piston roller ¹	1	1	Steel	
22	Spring guide ¹	--	1	Aluminum	
23	Spring external ¹	--	1	Sizes 210-260: Alloyed spring steel 270, 280 Spring steel	Corrosion protected
24	Spring internal ^{1,5}	--	1	Alloyed spring steel	Corrosion protected
25	Spring housing ¹	--	1	Aluminum	Anodized
26	Pre-tensioning screw ¹	--	1	Sizes 210-260: Stainless steel 270, 280: Steel	Zinc plated
27	Indicator	1	1	Polymer material	
28*	O-ring ¹	--	1	Nitrile	
29	Lock nut ¹	--	1	Sizes 210-260: Stainless steel 270, 280 Spring steel	Zinc plated
30	Marking washer ¹	--	1	Aluminum	Anodized
31*	Circlip, upper	1	1	Sizes 210-260: Stainless spring steel 270, 280: Spring steel	Corrosion protected
32*	Middle Washer	1	1	Sizes 210-260: Stainless steel 270, 280: Steel	Corrosion protected
33*	Support washer, upper	1	1	Polymer material, chemically resistant	
34	Seal ¹	1	1	Sizes 210-260: Stainless steel 270, 280: Nitrile	
35	Support ring, lower	1	1	Polymer material	
36	Bearing, lower	1	1	Polymer material	
37	Guide ring	1	1	Polymer material	
38*	O-ring, lower	1	1	Nitrile	
39*	Support washer, lower	1	1	Polymer material, chemically resistant	
40*	Circlip	1	1	Sizes 210-260: Stainless spring steel 270, 280: Spring steel	Corrosion protected

1. For actuators sizes 220, 240, 260 and 280: double the quantity. 2. RC 240 has triple roll pins.

3. RC 270-280 have steel pin. 4. Not shown. Does not exist for sizes 220, 240, 260 and 280.

5. Only for sizes 270 and 280.

* = Parts are contained in "Seal Kit" these are "Recommended Spare Parts".

TIGHTENING TORQUES FOR SCREWS AND LOCK NUTS

The actuators must be screwed onto the mounting brackets with the correct torque in order to be stable during operation. Use maximum screw length possible without the threads bottoming. Tightening torque values are expressed in in.-lb.

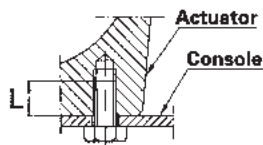

Actuator	End Plate Screw	Locknut	
		DA	SR
	(4)	(2)	(29)
RC 210-220	49	177	80
RC 230-240	49	354	159
RC 250-260	204	797	310
RC 270-280	673	1062	708

Actuator	DIN Flange	Thread	Lmax (mm)	Screw Length (mm)										
				32 (8)	.39 (10)	.47 (12)	.55 (14)	.63 (16)	.71 (18)	.79 (20)	.94 (24)	1.10 (28)	1.26 (32)	
RC 210	F05	1/4"	.43 (11)	88	91									
RC 220	F05	1/4"	.43 (11)	88	91									
RC 230-240	F07	5/16"	.55 (14)		168		186							
	F10	3/8"	.67 (17)				283		319					
RC 250-260	F10	3/8"	.67 (17)				283		319					
	F12	1/2"	.83 (21)					611	708	761	761			
RC 270	F14	5/8"	.98 (25)						1018	1151	1274	1522		
	170 X 110	5/8"	.98 (25)						1018	1151	1274	1522		
	F12	1/2"	.98 (25)						708	761	761	761		
RC 280	F16	3/4"	1.26 (32)									2080	2451	2682
	F25	5/8"	.98 (25)						1018	1151	1274	1522		