

E Series - Direct Mount - TECHNICAL DATA

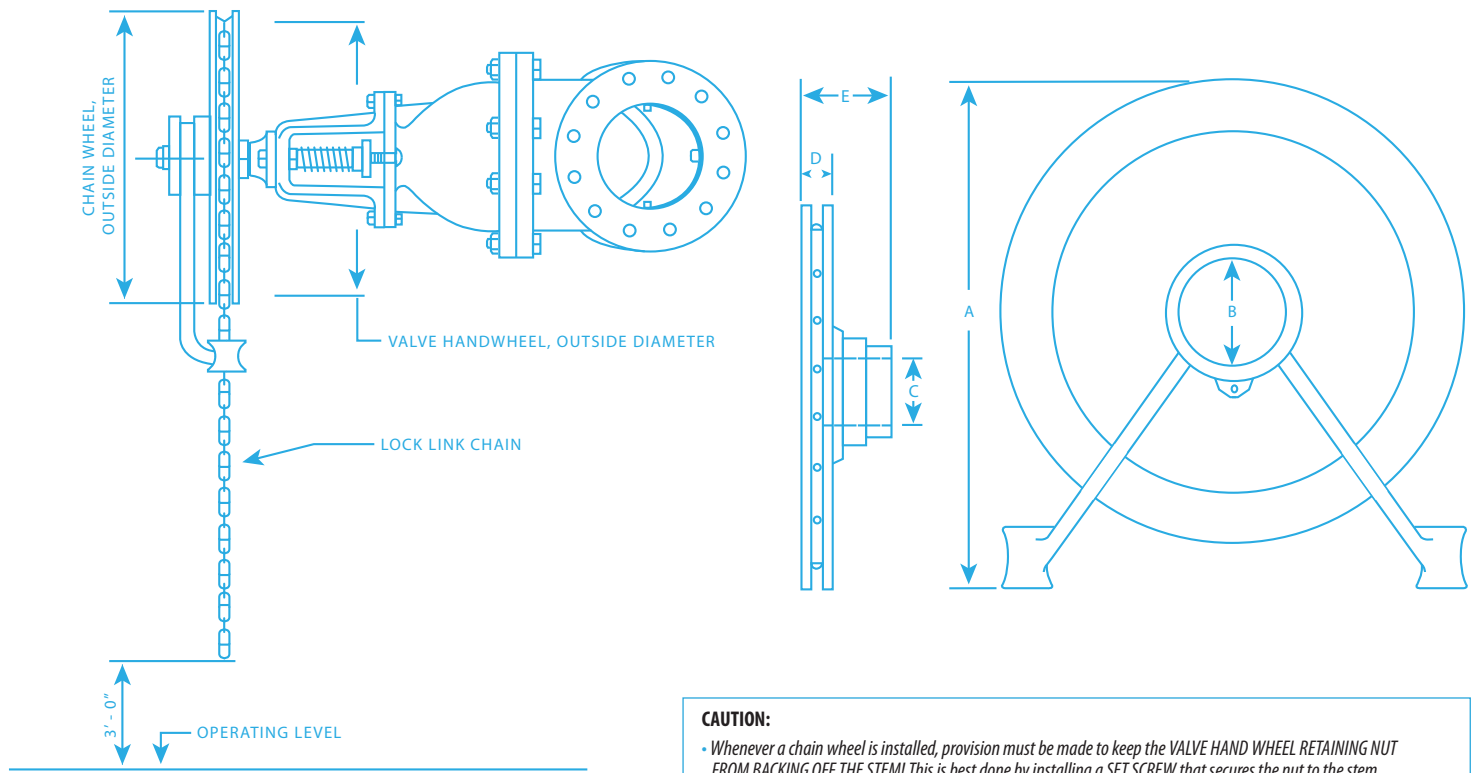

CAUTION:

- Whenever a chain wheel is installed, provision must be made to keep the VALVE HAND WHEEL RETAINING NUT FROM BACKING OFF THE STEM! This is best done by installing a SET SCREW that secures the nut to the stem.
- All chain wheel installations, regardless of age, must be regularly inspected as part of the user's Safety/Maintenance procedures. Set screws and other threaded fasteners MUST be secure and tight.
- As an additional safeguard, Roto Hammer strongly recommends that ALL chain wheels be fitted with an appropriately sized ROTO HAMMER RETAINING CABLE SAFETY KIT available from your local distributor or Roto Hammer Industries.
- Maintain Handwheel and Operator - Retention of the chain wheel operator on valve stem is dependent on the handwheel remaining on the valve stem. The handwheel retaining nut MUST be secured with a set screw.

CHAIN WHEEL DIMENSIONAL DATA

SPROCKET SIZE	E-6	E-9	E-12	E-15	E-18	E-24	E-30
A - OVERALL HEIGHT	7.370	9.750	12.750	15.620	18.750	24.370	33.000
B - HUB DIAMETER	1.500	2.870	3.190	4.250	4.250	4.250	4.250
C - MAX. BORE	1.000	2.370	2.690	3.750	3.750	3.750	3.750
D - RIM THICKNESS	1.120	1.370	1.370	1.870	1.870	1.870	1.870
E - OVERALL DEPTH	2.560	3.250	3.250	3.930	4.620	4.620	4.810

CHAIN OPERATOR SELECTION

HAND WHEEL OUTSIDE DIAMETER	CHAIN OPERATOR	CHAIN WHEEL OUTSIDE DIAMETER	CHAIN SIZE REQUIRED	ROTO LINK REQUIRED	SAFETY CABLE REQUIRED
UP TO 6"	E-6	6-3/16"	#2	RL#2	RCK 3/16
6" TO 9"	E-9	8-9/16"	1/0	RL 1/0	
9" TO 12"	E-12	12-3/4"	1/0	RL 1/0	
12" TO 15"	E-15	15"	4/0	RL 4/0	RCK 1/4
15" TO 18"	E-18	18-1/4"	4/0	RL 4/0	
18" TO 24"	E-24	24-1/4"	5/0	RL 5/0	RCK 5/16
24" AND OVER	E-30	30-1/4"	5/0	RL 5/0	

