

Medical Sterile Filters

Models | A30015MS to A31500MS

Flow Rates 15 SCFM (25 Nm³/hr) to 1500 SCFM (2550 Nm³/hr)

When it comes to patient care, quality and reliability of compressed air is paramount. Walker Filtration's range of Alpha Medical Sterile Filters guarantees reliable and outstanding air purity that meets internationally certified medical performance levels.

100% integrity tested, Alpha Medical Sterile elements are guaranteed for a minimum of 100 sterilizations at 248°F (120°C), ensuring your compressed air is free from live bacteria and other submicron particles.



Stainless Steel End Caps

Specially designed for autoclave sterilization compatibility



100% Integrity Tested

Each element is supplied with an Air Sterilization Certificate to guarantee the highest quality to our customers



Product Safety in Mind

Lock indication arrows assure effective sealing

- **International Validation** Designed to exceed the requirements of HTM 02-01 medical gas pipeline systems
- **Simplified Serviceability** Ribbed bowl design and unique push fit elements ensure quick and reliable maintenance
- **Product Safety in Mind** Guaranteed safe housing closure with rotational safety stop
- **Corrosion Protection** Internal and external electrophoretic paint finish followed by a tough polyester powder coating
- **Flexible Installation** Modular design and accessible fixings enable simple close coupling assembly
- **Robust and Sterilizable Materials** Manufactured from cast aluminum alloy for enhanced strength and protection

For further information please visit www.walkerfiltration.com



Designed to exceed the requirements of HTM 02-01 Technical Memorandum



For further information please call: +1 814 836 2900



Technical Specification

Filter model	Pipe size inches	Inlet flow rate*		Dimensions inches (mm)				Weight		Element model
		SCFM	Nm ³ /hr	A	B	C	D	lbs	kg	
A30015MS	1/4	15	25	1.97 (50)	0.67 (17)	6.18 (157)	2.36 (60)	0.6	0.3	E30306SR
A30025MS	1/4	25	42	2.76 (70)	0.91 (23)	9.09 (231)	2.76 (70)	1.3	0.6	E30408SR
A30032MS	3/8	32	54	2.76 (70)	0.91 (23)	9.09 (231)	2.76 (70)	1.3	0.6	E30408SR
A30050MS	1/2	50	85	2.76 (70)	0.91 (23)	9.09 (231)	2.76 (70)	1.3	0.6	E30412SR
A30070MS	1/2	70	119	5.00 (127)	1.26 (32)	11.22 (285)	3.15 (80)	3.7	1.7	E30612SR
A30085MS	3/4	85	144	5.00 (127)	1.26 (32)	11.22 (285)	3.15 (80)	3.7	1.7	E30612SR
A30175MS	1	175	297	5.00 (127)	1.26 (32)	14.57 (370)	3.15 (80)	4.4	2.0	E30621SR
A30280MS	1 1/4	280	476	5.51 (140)	1.61 (41)	18.74 (476)	3.35 (85)	6.6	3.0	E30731SR
A30320MS	1 1/2	320	544	5.51 (140)	1.61 (41)	18.74 (476)	3.35 (85)	6.6	3.0	E30731SR
A30400MS	1 1/2	400	680	6.69 (170)	2.09 (53)	20.00 (508)	3.94 (100)	10.8	4.9	E30831SR
A30450MS	2	450	765	6.69 (170)	2.09 (53)	20.00 (508)	3.94 (100)	10.8	4.9	E30831SR
A30700MS	2	700	1189	6.69 (170)	2.09 (53)	27.87 (708)	3.94 (100)	12.1	5.5	E30850SR
A30850MS	2 1/2	850	1444	8.66 (220)	2.76 (70)	28.98 (736)	3.94 (100)	23.1	10.5	E31140SR
A30900MS	3	900	1529	8.66 (220)	2.76 (70)	28.98 (736)	3.94 (100)	23.1	10.5	E31140SR
A31250MS	3	1250	2125	8.66 (220)	2.76 (70)	33.74 (857)	3.94 (100)	25.4	11.5	E31160SR
A31500MS	3	1500	2550	8.66 (220)	2.76 (70)	39.57 (1005)	3.94 (100)	27.6	12.5	E31175SR

* Rated flow at 100 psig (7 barg), reference conditions at 14.5 psi (a) (1 bar (a)) 68°F (20°C)

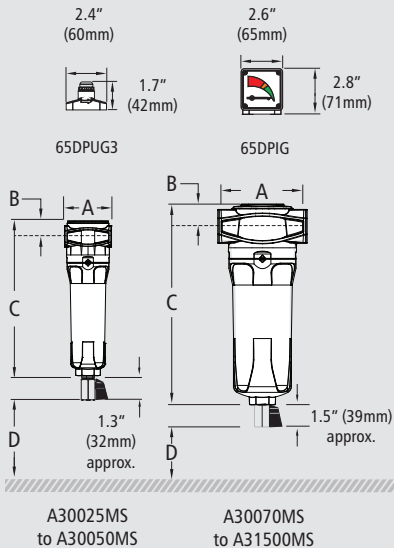

Grade	SR	
DOP efficiency**	>99.9999%	
Particle removal	0.01 micron	
Maximum operating temperature	248°F	120°C
Recommended operating temperature	122°F	50°C
Maximum autoclave temperature	273°F	134°C
Pressure Loss - clean & dry	1.5 psi	100 mbar
Maximum working pressure	300 psig	20.7 barg
Element end cap material	Stainless steel	

** As specified in HTM 02-01 medical gas pipeline systems

Pressure correction factors	For maximum flow rate, multiply model flow rate by the correction factor corresponding to the minimum operating pressure									
Operating pressure psig (barg)	58 (4)	72 (5)	87 (6)	100 (7)	115 (8)	145 (10)	174 (12)	203 (14)	232 (16)	300 (20.7)
100 psig correction factor	0.76	0.84	0.92	1.00	1.07	1.19	1.31	1.41	1.51	1.73

Technical notes

- Filter element end caps are stainless steel.
- Direction of air flow is outside to in through the filter element.
- Pop up indicators (65DPUG3) are fitted to models A30025MS to A30050MS as standard. Differential pressure indicators (65DPIG) are fitted to models A30070MS to A31500MS as standard.
- Manual drain valves (MDV25 on models A30015MS to A30050MS and MDVE25B on models A30070MS to A31500MS) are fitted as standard.
- Medical Sterile Filter elements must not operate in water or oil saturated conditions.
- Maximum steam sterilizing temperature refers to the filter element ONLY. Grade SR filter elements can be steam sterilized 100 times. Each element must be autoclaved before commencement of duty.
- Pre-filtration should be used in conjunction with 0.01 micron sterile filters.
- Threaded filters are manufactured from cast aluminum alloy and are PED 2014/68/EU compliant for group 2 gases.
- Standard threaded connections are NPT to ANSI/ASME B1.20.1. RP (BSP Parallel) to ISO 7-1 and RC (BSP Taper) to ISO 7-1 are also available upon request.
- Filter elements should be changed at least every 6 months or every 100 sterilizations, whichever comes first.
- Filters are suitable for use in dry air conditions only, as any liquids passing through the filter could carry bacteria and compromise sterility.

